



GENUINE PARTS

INSTALLATION INSTRUCTIONS

- 1. DESCRIPTION:** Fog Lamp Kit
2. APPLICATION: Titan MY16
3. PART NUMBER(S) REQUIRED FOR INSTALLATION: 999F1 W4000 Fog Lamp Kit

4. KIT CONTENTS:

Item	Qty.	Part Description	Service Part Number
A	2	Fog Lamp Assembly	26150 9B90D
B	1	Fog Lamp Finisher, RH	62256 EZ02B
C	1	Fog Lamp Finisher, LH	62257 EZ02B
D	1	Switch Assy	25370 1PA0A
E	6	Scr-Tap, Hex Hd Flg Tp 4 6	81-46616-5G
F	1	II Replacement Template	999V2 AW000
G	N/A	Installation Instructions	999F1 W4000II

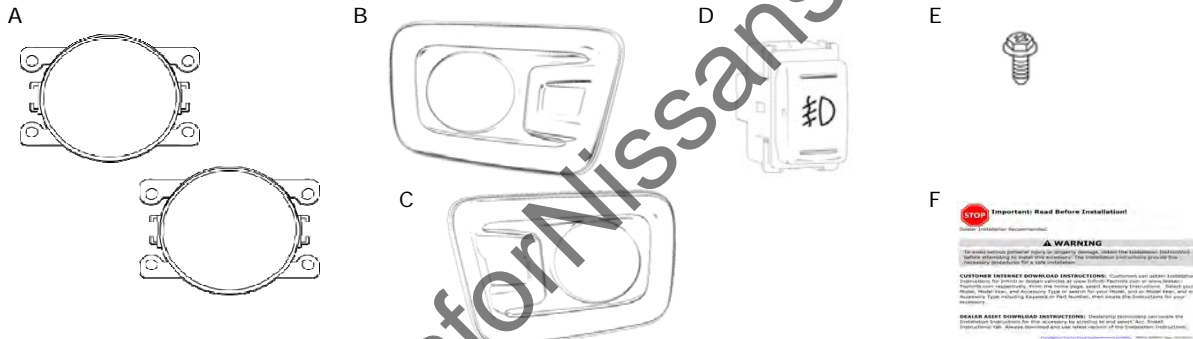

5. TOOLS REQUIRED:

- Nylon Trim Tool
- Short 1/4" ratchet drive
- 1/4" Drive 10mm Socket
- Standard #2 Phillips Screwdriver
- Short #2 Philips screwdriver
- 10mm Ratcheting Wrench
- Flashlight
- Masking tape

6. PRE-INSTALLATION CAUTIONS/NOTES:

- Dealer Installation Highly Recommended. Instructions may refer to Service Manual.
- Read the Installation Instructions thoroughly and follow the steps exactly as described.
- Please **DO NOT** use or install the part in ways other than what is described in this instruction manual.
- Use of a lift is recommended for ease of installation.

⚠ CAUTION

- Be sure to use seat and floor protection during installation.
- Ensure that all parts are securely fitted and will not compromise the safe function of vehicle systems.

INSTALLATION INSTRUCTIONS

7. VEHICLE PREPARATION

⚠ CAUTION

- Always confirm the ignition is in the "OFF" position before changing the E.S.S. position.

- 1) Apply parking brake
- 2) Confirm vehicle is no longer in default shipping state (Extended Storage Switch Pulled Up and BCM in Transit Mode). Failure to confirm vehicle has been removed from this state will result in loss of normal vehicle operation. Confirmation requires two checks:

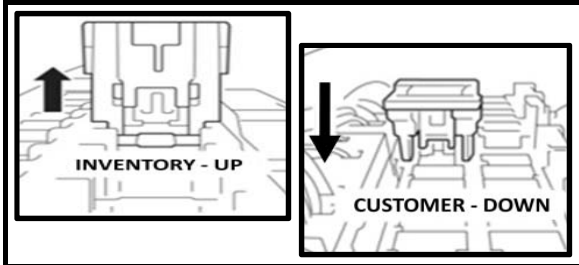

- 3) Locating Extended Storage Switch.
 - a) Locate Extended Storage Switch in cabin fuse block.
 - b) Check that Extended Storage Switch is in "Customer" position. As shown left for reference.

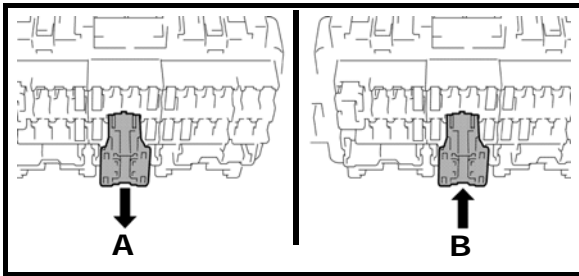

- 4) Engage and remove from transit mode
 - a) To engage transit mode, pull out in **A** direction as shown in the figure.
 - b) To remove from transit mode, press in **B** direction as shown in the figure.

Condition	Switch Position	Note
Vehicle is delivered to the dealer	Inventory Condition	
Technician performs PDI	Customer Delivery	Return switch to Inventory position after PDI.
Customer test drives the vehicle	Customer Delivery	Return switch to Inventory position after test drive.
Vehicle is being stored at the dealer	Inventory Condition	
Vehicle is sold and delivered to customer	Customer Delivery	

- 5) Turn ignition switch to "ON" position
- 6) Record the customer radio presets and other presets as required below:

Preset	1	2	3	4	5	6		

- 7) Put shift lever in "P" position for A/T and CVT or "1st" for M/T
- 8) Turn ignition switch to "OFF" position

8. CRITICAL STEPS

The following steps must be performed **Exactly** as specified to ensure proper installation:

- Placement of the fog lights is fixed, lamps can only be installed in the described location.
- Apply masking tape as needed to protect any areas that could be scratched or damaged by tools.
- Test the functionality of the kit before final clean up and reinstallation of exterior and interior panels.

INSTALLATION INSTRUCTIONS

9. INSTALLATION OVERVIEW:

1.) SYSTEM

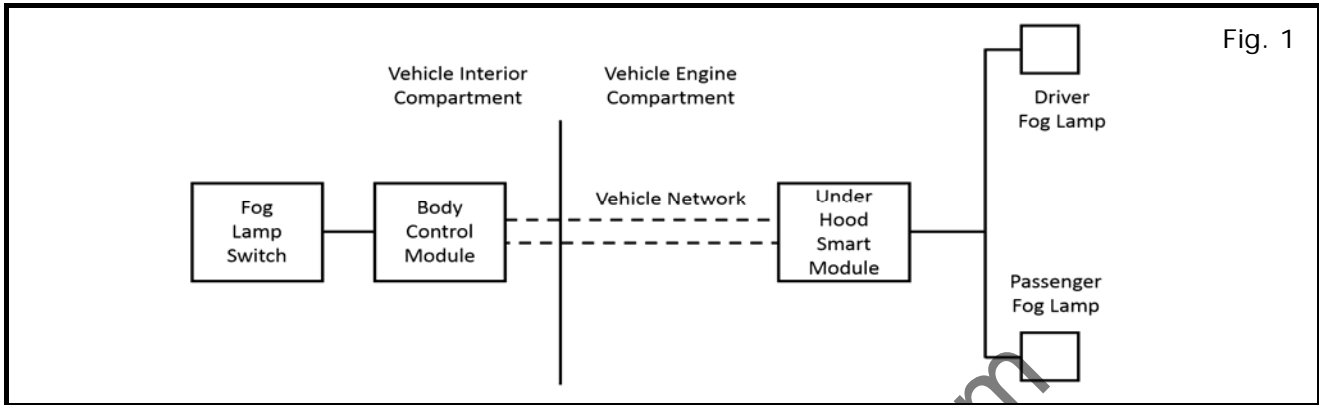

Fig. 1

2.) VEHICLE

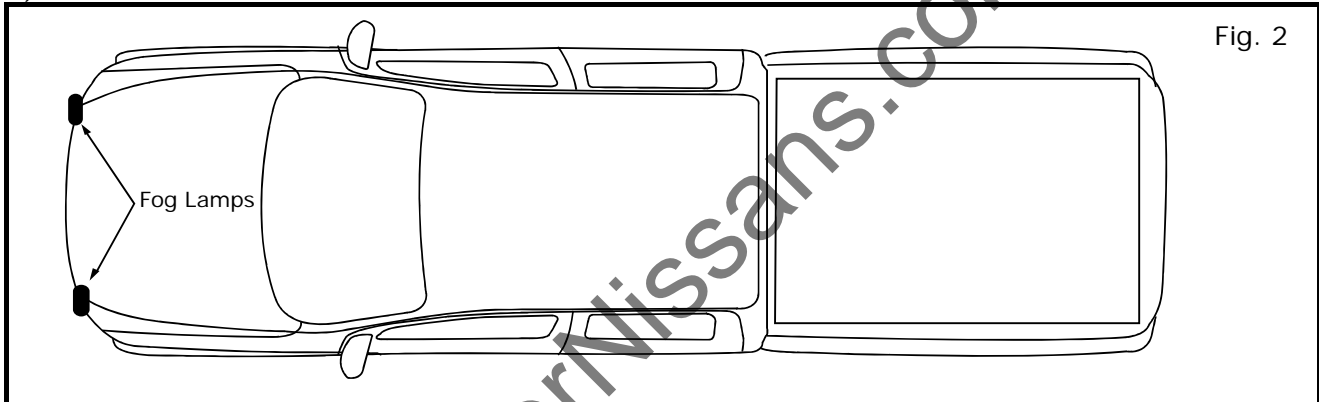

Fig. 2

⚠ WARNING

- ALWAYS work from the side of an air bag module. NEVER work directly in front of it.

⚠ CAUTION

- Take care not to scratch or damage any component during the removal or re-installation process.
- Trim pieces found to have witness marks or broken clips ARE NOT to be reinstalled.
- Always remove vehicle parts in the sequence directed, improper procedure can damage parts.
- Store removed parts in a safe and protected manner.

10. ORDER OF INSTALLATION:

- 1.) Gently remove the fascia finisher panels.
- 2.) Install fog lamp assemblies.
- 3.) Install and secure fog lamp finishers.
- 4.) Gently remove the lower IP trim panel.
- 5.) Install fog lamp switch.
- 6.) Carefully replace all panels and trim.

INSTALLATION INSTRUCTIONS

11 INSTALLATION PROCEDURE:

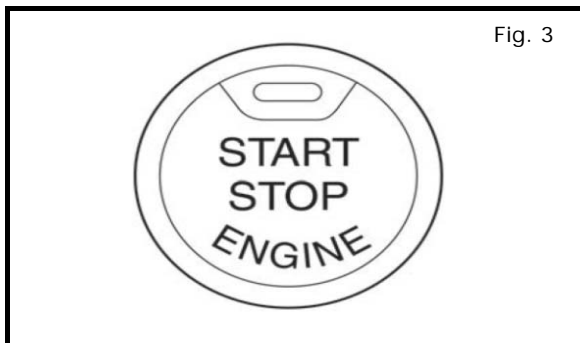

- 1) Unlocking steering wheel
 - a) Push ignition switch in without depressing brake pedal once to change to ACC position as shown in Fig. 3.

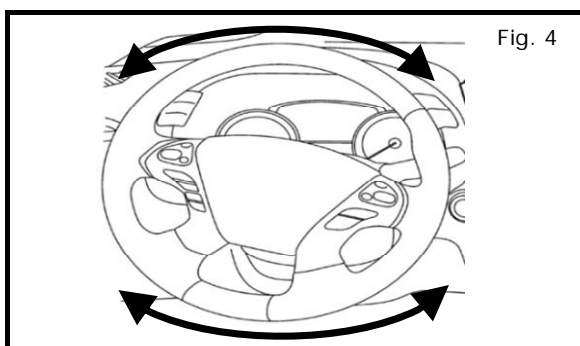

- 2) Unlocking steering wheel
 - a) Rotate steering wheel to left and right side be sure it is unlocked before proceeding as shown in Fig. 4.

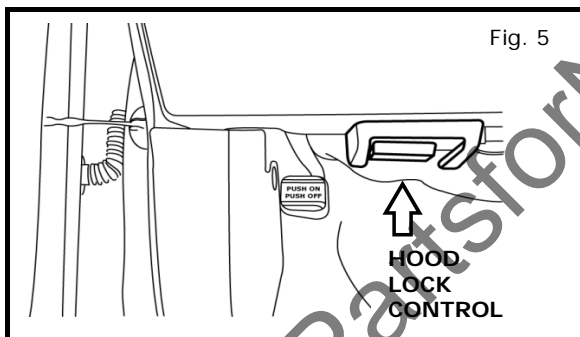

- 3) Opening hood.
 - a) Pull hood lock release handle located in lower LH section of IP under steering wheel area as shown in Fig. 5.

CAUTION

- Close all doors and allow 3 min after key off for vehicle to time out .

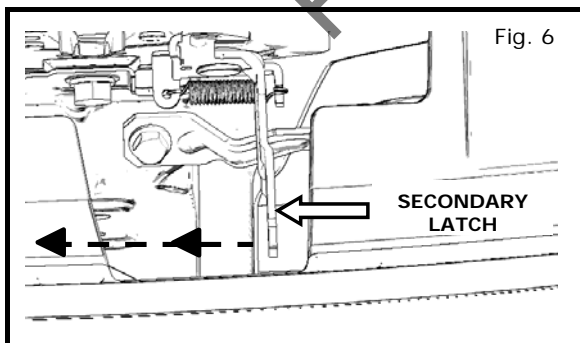

- 4) Opening hood.
 - a) Push the lever at the front of the hood to the side as illustrated with your fingertips and raise the hood as shown in Fig. 6.

INSTALLATION INSTRUCTIONS

11 INSTALLATION PROCEDURE:

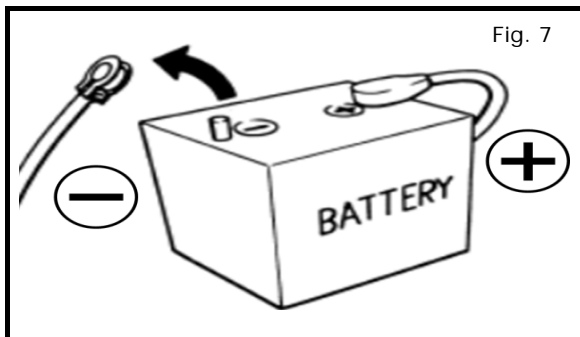

Fig. 7

- 5) Disconnecting battery terminal(s).
 - a) Using the 1/4 ratchet and 10mm socket loosen Negative battery terminal. Remove and isolate negative terminal from the negative post as shown in Fig. 7.

⚠ CAUTION

- Allow an additional 3 min after negative terminal dis-connect before separating any electrical connectors.

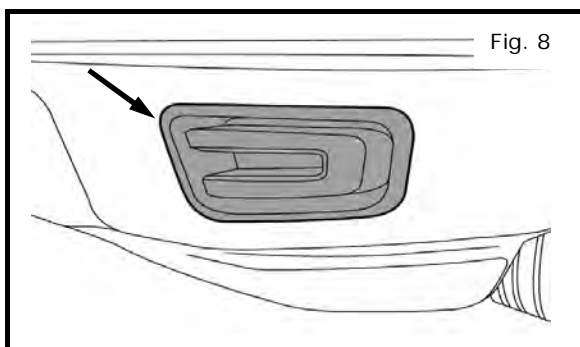

Fig. 8

- 6) Removing fascia finisher.
 - a) Carefully pry at corner of LH side fascia finisher cover with trim tool to release retaining tabs on inside of fascia as shown in Fig. 8.

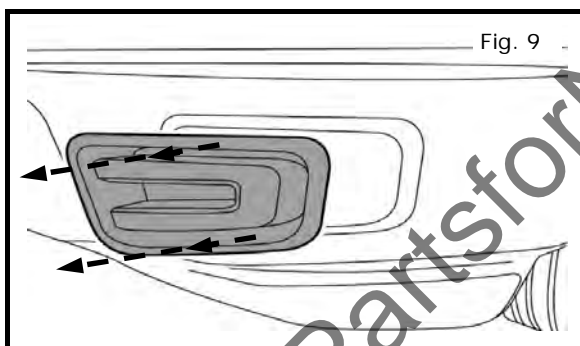

Fig. 9

- 7) Removing fascia finisher.
 - a) Remove fascia finisher from fascia as shown in Fig. 9.

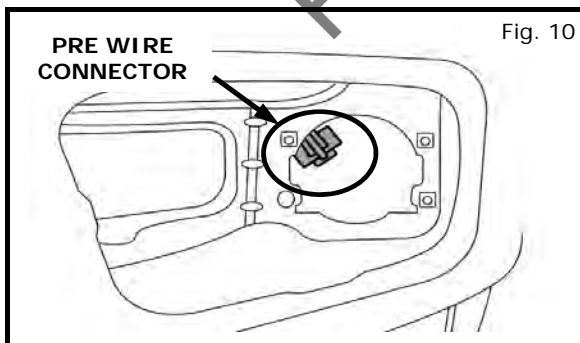
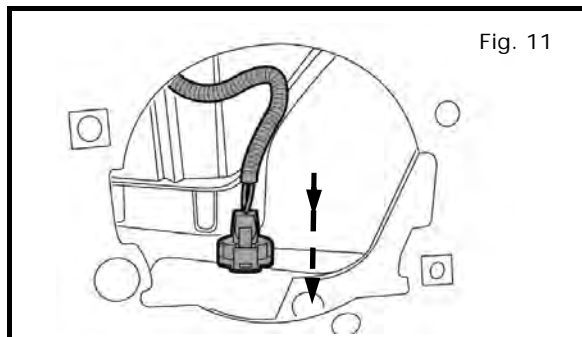

Fig. 10

- 8) Installing fog lamp.
 - a) Locate fog lamp prewire connector inside of fascia as shown in Fig. 10.

INSTALLATION INSTRUCTIONS

11 INSTALLATION PROCEDURE:



- 9) Installing fog lamp.
a) Carefully remove tear away tape from fog lamp pre wire connector and pull down as shown in Fig. 11.

▲ CAUTION

- Remove by connector, never pull on wire to free a connector.

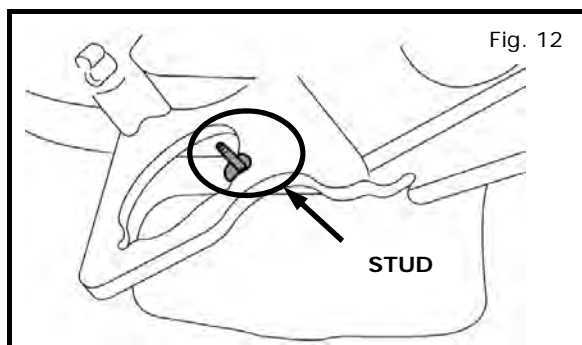

- 10) Installing fog lamp.
a) Find fog lamp locator stud for fog lamp as shown in Fig. 12.

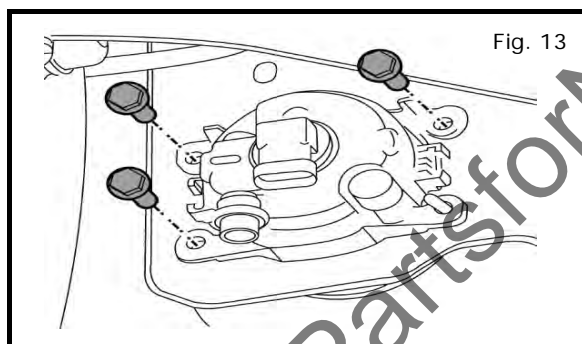

- 11) Installing fog lamp.
a) Place fog lamp assembly into position from inside fascia as shown.
b) Once fog lamp assembly is in position hand start fasteners as shown in Fig. 13.

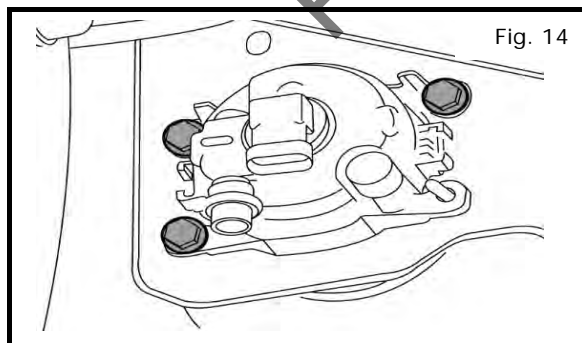

- 12) Installing fog lamp.
a) Mounting fog lamp in position
b) Torque fastener to 5.5 Nm (+/-0.5).

INSTALLATION INSTRUCTIONS

11 INSTALLATION PROCEDURE:

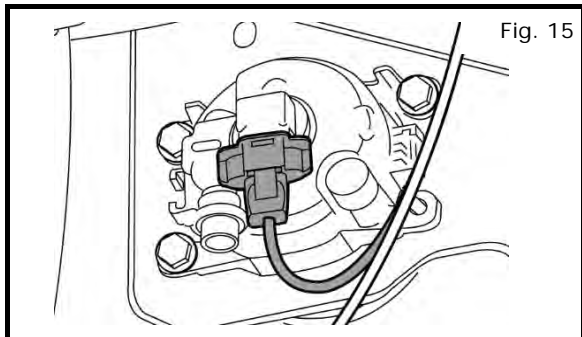

- 13) Installing fog lamp.
a) Connect pre-wire harness connector to fog lamp assembly as shown in Fig. 15.

▲ CAUTION

- Make sure all connectors being reinstalled are fully seated and locked before proceeding with assembly process.

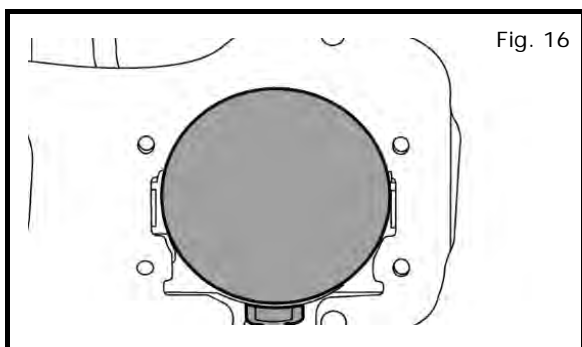

- 14) Installing fog lamp.
a) Fog lamp should look as shown in Fig. 16.

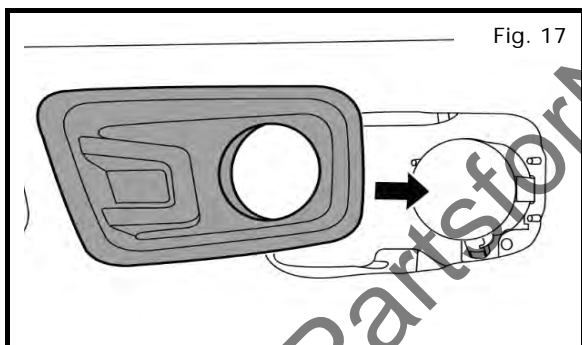

- 15) Installing fascia finisher.
a) Press finisher assembly into position from front of fascia. Press finisher firmly until mounting clips snap into position as shown in Fig. 17.

NOTE: Be sure clips are fully seated before proceeding.

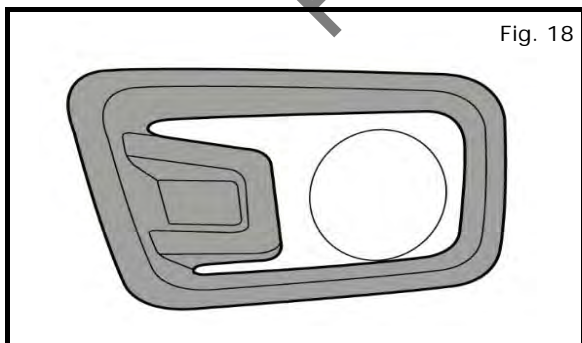

- 16) Installing fascia finisher.
a) Make certain finisher assembly is fully seated in position in front fascia before proceeding as shown in Fig. 18.

NOTE: Repeat steps 6 through 16 on RH side of vehicle.

INSTALLATION INSTRUCTIONS

11 INSTALLATION PROCEDURE:

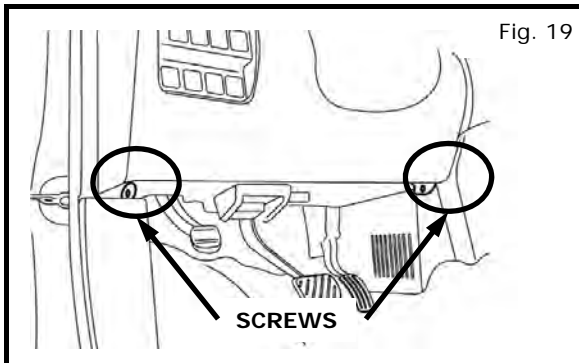

- 17) Removing lower IP cover trim.
- a) Locate the two (2) screws securing lower IP trim as shown in Fig. 19.

⚠ WARNING

- Always work from the side of air bag module, never work directly in front of it.

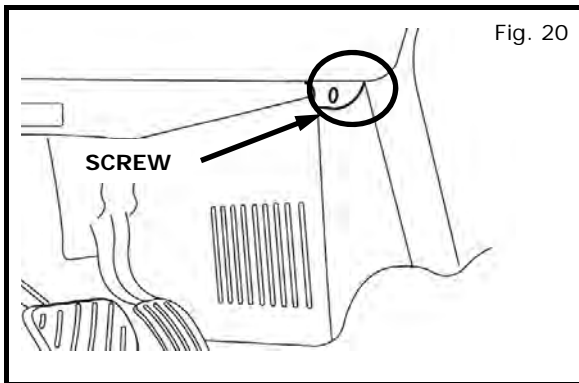

- 18) Removing lower IP cover trim.
- a) Remove one (1) phillips head screw next to center console as shown in Fig. 20.

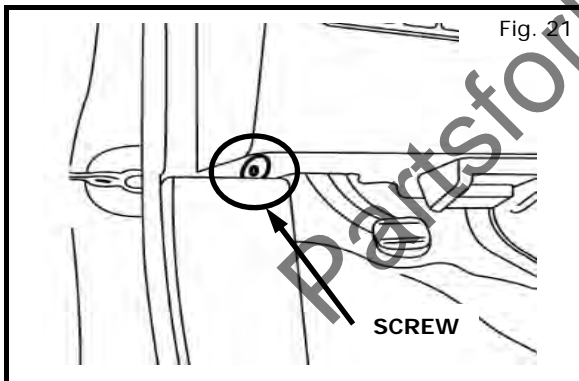

- 19) Removing lower IP cover trim.
- a) Remove one (1) phillips head screw as shown in Fig. 21.

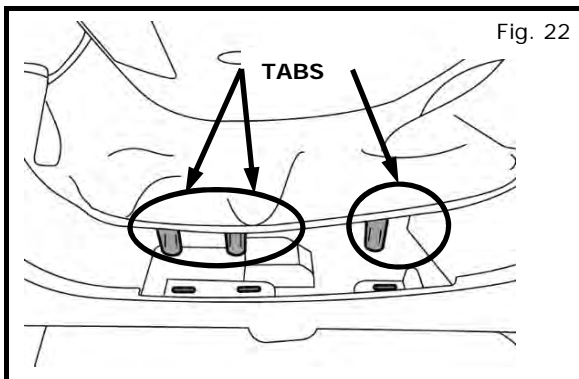

- 20) Removing lower IP cover trim.
- a) Gently pull lower IP cover trim loose from dash.
- b) Carefully separate lower IP cover trim from steering column gap cover by removing tabs as shown in Fig. 22.

INSTALLATION INSTRUCTIONS

11 INSTALLATION PROCEDURE:

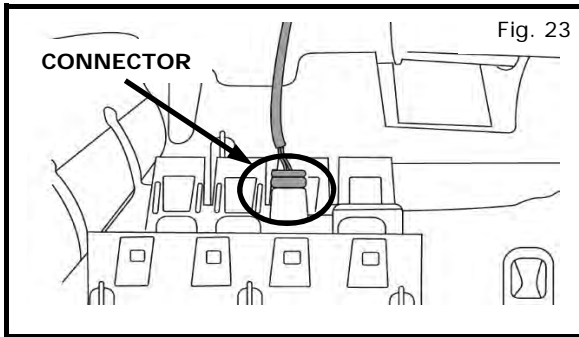

- 20) Removing lower IP cover trim.
- Gently roll lower IP cover trim forward from dash.
 - Carefully remove any connectors in switch bank as shown in Fig. 23.

⚠ CAUTION

- Take care not to scratch or damage any component during the removal process.
- Trim pieces found to have witness marks or broken clips are not to be reinstalled.

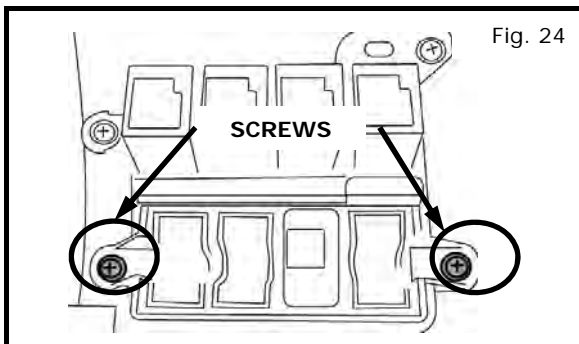

- 22) Removing switch bank.
- Remove two (2) phillips screws from upper switch bank as shown in Fig. 24.

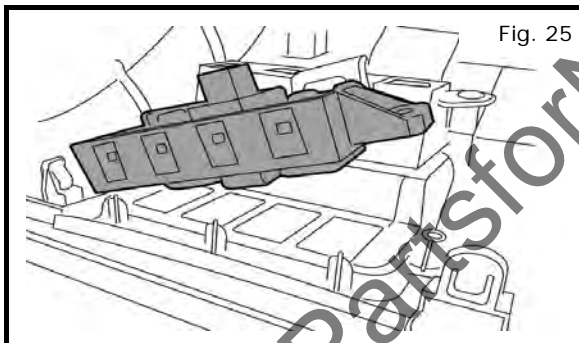

- 23) Removing switch bank.
- Gently remove upper switch bank from lower IP cover trim as shown in Fig. 25.

NOTE: Note the orientation switch bank in trim panel as well as existing switches location.

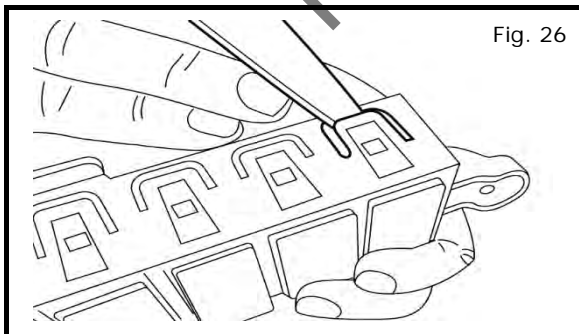

- 24) Removing switch blank.
- Using a non marring trim tool release lock tabs on RH end switch blank while gently pressing on front of switch blank to remove as shown in Fig. 26.

⚠ CAUTION

- Take care not to stress or damage any component during the removal process.

INSTALLATION INSTRUCTIONS

11 INSTALLATION PROCEDURE:

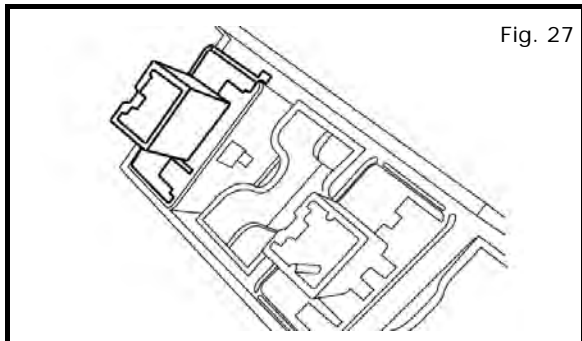

- 25) Installing fog lamp switch.
a) Insert fog lamp switch into switch bank as shown in Fig. 27.

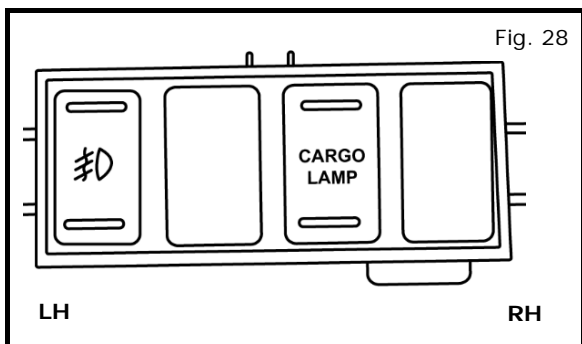

- 26) Installing fog lamp switch.
a) Switch bank should look similar to illustration (depending on options) shown in Fig. 28.

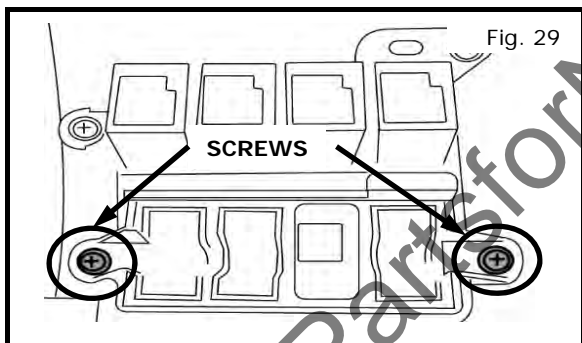

- 27) Installing fog lamp switch.
a) Install upper switch bank into lower IP cover trim using two (2) phillips screws as shown in Fig. 29.

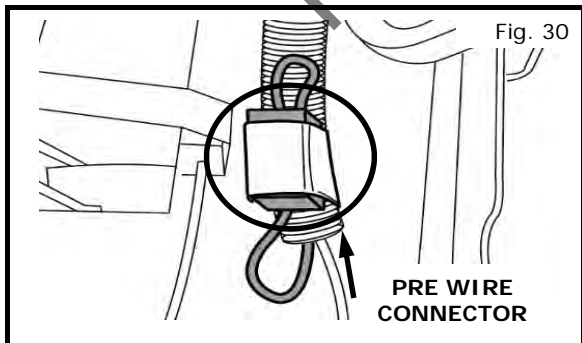

- 28) Installing fog lamp switch.
a) Locate fog lamp switch prewire as shown in Fig. 30.

INSTALLATION INSTRUCTIONS

11 INSTALLATION PROCEDURE:

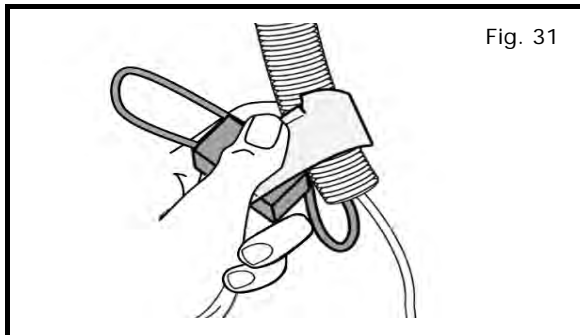

- 29) Installing fog lamp switch.
- Carefully remove tear away tape from fog lamp switch prewire connector as shown in Fig. 31.

CAUTION

- Remove by connector, never pull on wire to free a connector.

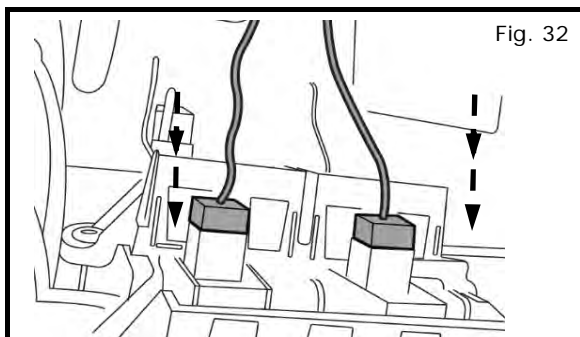

- 30) Installing fog lamp switch.
- Connect fog lamp switch prewire connector as shown in Fig. 32.
 - Reconnect any connectors in switch bank that were removed as shown in Fig. 32.

CAUTION

- Make sure all connectors being reinstalled are fully seated and locked before proceeding with assembly process.

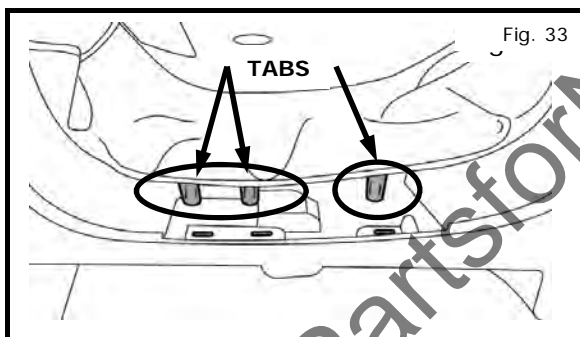

- 31) Installing lower IP cover trim.
- Gently insert steering column gap cover into lower IP cover trim as shown in Fig. 33.

CAUTION

- Make sure all tabs being are fully seated and locked before proceeding with Installing lower IP cover trim.

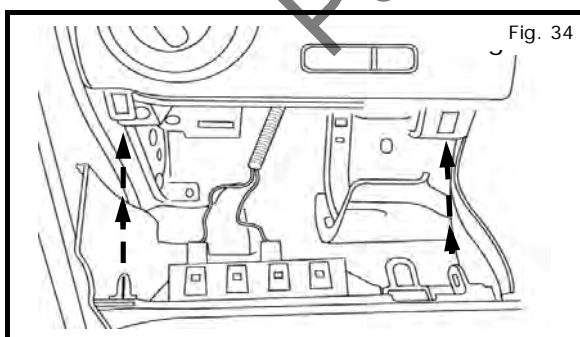

- 32) Installing lower IP cover trim.
- Gently push lower IP cover trim back into position in dash as shown in Fig. 34.

CAUTION

- Take care not to scratch or damage any component during the removal process.
- Trim pieces found to have witness marks or broken clips are not to be reinstalled.

INSTALLATION INSTRUCTIONS

11 INSTALLATION PROCEDURE:

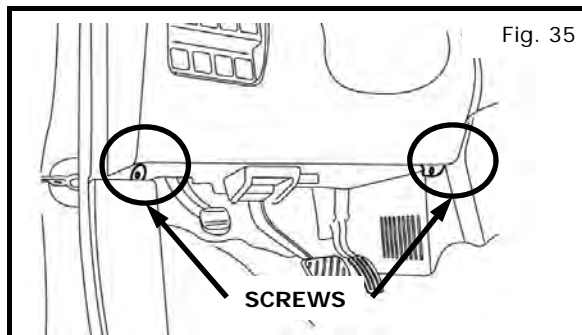

- 33) Installing lower IP cover trim.
- a) Install two (2) screws to secure lower IP trim as shown in Fig. 35.

▲ WARNING

- Always work from the side of air bag module, never work directly in front of it.

12. ACCESSORY FUNCTION CHECK:

▲ CAUTION

- Make sure all connectors are engaged and locked before proceeding with accessory check.

- Connect battery negative terminal and tighten terminal nut to 5.4 N·m (47.8 lb-in).
- Push ignition button twice (without depressing gas pedal) to put vehicle in ACC position.
- Turn headlamp and fog lamp switches to ON position.
- Verify headlamps, fog lamps and tail lamps are illuminated.
- Verify headlamps and fog lamp indicators are illuminated on meter assembly.
- Verify turn signal, hazard and high beam functionality.
- Verify turn signal, hazard and high beam indicators are illuminated on meter assembly.
- Verify wiper and washer functionality.
- Turn headlamp switch to the OFF position, leaving the fog lamp switch in ON position.
- Verify both headlamp and fog lamps turn off.

INSTALLATION INSTRUCTIONS

13. FINAL INSPECTION:

CAUTION

- Refer to the vehicle service manual for more information on the procedures outlined below

- Inspect installation area for any debris.
- Verify re-installed trim parts for proper flush fit (no gaps, no waviness, etc.).
- Verify all clips are fully engaged and locked.
- Verify re-installed trim parts are free from cracks, scratches or stress marks.
- Verify vehicle headliner, seat, steering wheel, center console, floor carpets, etc. are not soiled.
- Verify interior and exterior is not damaged.

14. VEHICLE SYSTEMS CHECK:

CAUTION

- Refer to the vehicle service manual for more information on the procedures outlined below

- Turn ignition switch to "ON" and confirm proper operation of the following vehicle systems and verify:
 - Confirm proper audio function (AM, FM, SAT, CD and AUX) and re-program radio presets.
 - That there are no new Diagnostic Trouble Codes.
 - Verify all windows and sunroof (if equipped), one touch operation and perform the reset procedure if necessary. Refer to the vehicle service manual for more details.
 - Tail Lamp - Turn on headlamps; open glove box and note whether light goes on.
 - Start vehicle. Note if vehicle does not start.
- Re-program radio presets and other vehicle settings to the recorded settings.
- Front Sonar Module Connector (if equipped) - Turn on vehicle, put vehicle in 'Drive'. Move slowly towards a large object in front of the vehicle. Note whether alarm sounds.
- Rear Sonar Module Connector (if equipped) - Turn on vehicle, put vehicle in 'Reverse'. Move slowly towards a large object behind the vehicle. Note whether alarm sounds.

INSTALLATION INSTRUCTIONS

14. BILL OF MATERIALS:

999F1 W4000 Titan Fog Lamp Kit

Item	Part Description	Qty.	Service Part Number
A	Fog Lamp Assembly	2	26150 9B90D
B	Fog Lamp Finisher, RH	1	62256 EZ02B
C	Fog Lamp Finisher, LH	1	62257 EZ02B
D	Switch Assy	1	25370 1PA0A
E	Scr-Tap, Hex Hd Flg Tp 4 6	6	81-46616-5G
F	II Replacement Template	1	999V2 AW000
G	Installation Instructions	N/A	999F1 W4000I1

PartsforNissans.com

INSTALLATION INSTRUCTIONS

15. Mechanization:

CAUTION

- Refer to the vehicle service manual for detailed schematic and connector information.

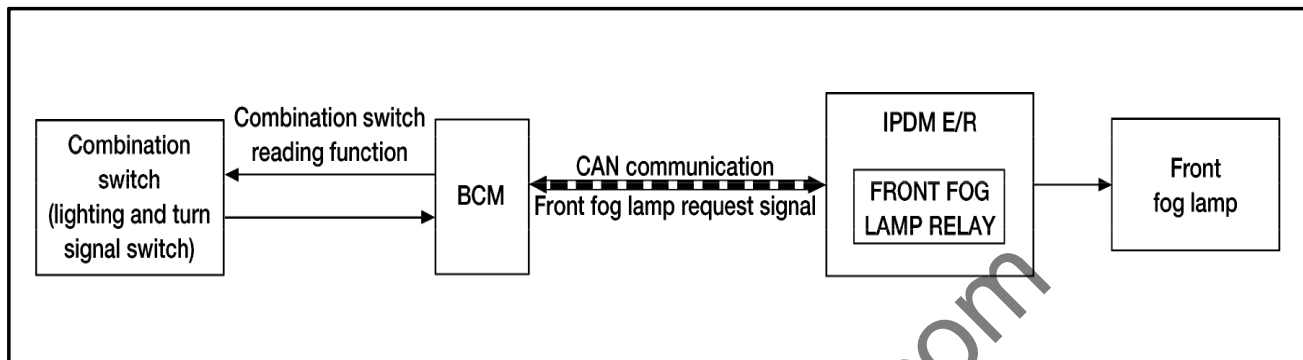

PartsforNissans.com