

Vehicle Preparation:

⚠ CAUTION

• Always confirm the ignition is in the "OFF" position before changing the switch condition.

- 1) Apply parking brake
- 2) Confirm vehicle is not in the default shipping state or "Inventory position" as shown below. Failure to confirm vehicle has been removed from this state will result in loss of normal vehicle operation.
- 3) Locate Extended Storage Switch in cabin fuse block. Confirm it is in the "Customer" position. See below for reference.
 - a) To remove transit mode (Fuse Block):
 1. Remove fuse cover lid.
 2. Push down shorting pin.
 3. Ign On 2 times without starting the vehicle.
 - b) To remove transit mode (BCM):
 1. Confirm ignition switch is in "OFF" position.
 2. Simultaneously push the signal and wiper switch fully down for two (2) seconds.

NOTE: While in BCM Transit Mode, turn signal indicators will remain illuminated for one minute.

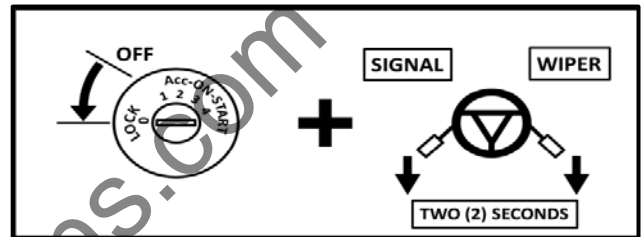
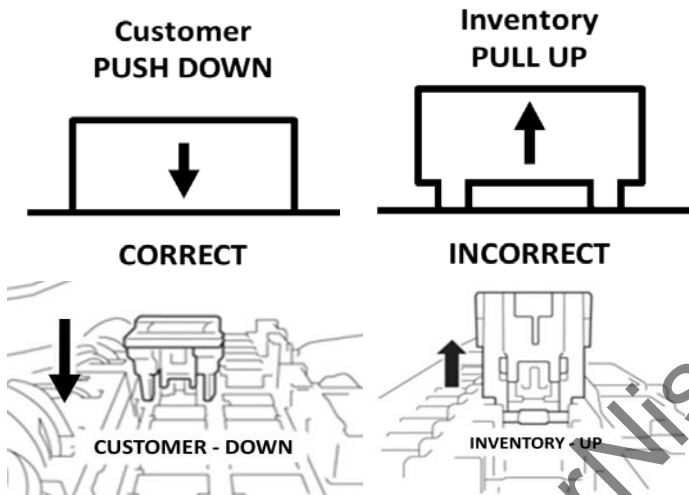

- c) To return to transit mode for storage:
 1. Ign Off.
 2. Remove fuse cover lid.
 3. Pull up shorting pin.
 4. Assemble fuse cover lid.
 5. Ign On 2 times without turn the vehicle on.
 6. Confirm transit mode condition on meter

NOTE: Typical vehicle condition shown above. Switch is easily identifiable by the permanent, push-pull fuse holder. Actual position on the fuse block may vary, vehicle to vehicle.

Condition	Switch Position	Note
Vehicle is delivered to the dealer	Inventory Condition	
Technician performs PDI	Customer Delivery	Return to Inventory position after PDI.
Customer test drives the vehicle	Customer Delivery	Return to Inventory position after test drive.
Vehicle is being stored at the dealer	Inventory Condition	
Vehicle is delivered to customer	Customer Delivery	

NOTE: The Extended Storage Switch is only an aid to improve battery life during vehicle storage at the dealer. If the Extended Storage Switch fuse ever needs service after vehicle delivery, discard the Extended Storage Switch and install the correct fuse in its place.

- 4) Turn ignition switch to "ON" position
- 5) Record the customer radio presets and other presets as required.

Presets	1	2	3	4	5	6		

- 6) Put shift lever in "P" position for A/T and CVT or "1st" for M/T
- 7) Turn ignition switch to "OFF" position
- 8) Use seat and floor protection.

INSTALLATION PROCEDURE: PRE-INSTALLATION CAUTIONS / NOTES

⚠ CAUTION

- Allow 3 min after key off and doors closed for vehicle to time out. Allow an additional 3 min after negative terminal dis-connect before separating any electrical connectors.

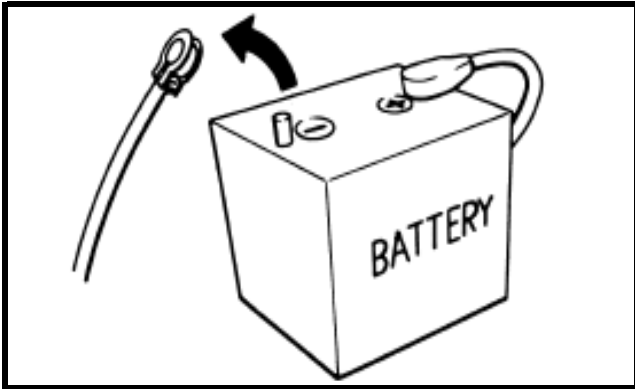

- 7) Disconnect the negative battery terminal(s).
- 8) Use seat and floor protection.
- 9) This part is to be installed at surface temperature of 65-100 deg.F.

⚠ CAUTION

- Take care not to scratch or damage any component during the removal or re-installation process.
- Trim pieces found to have witness marks or broken clips are not to be reinstalled.
- Additional items in cargo area may need to be removed.
- Always remove vehicle parts in the sequence they are shown, improper procedure can damage parts.
- Store removed parts in a safe and protected manner.

INSTALLATION OVERVIEW:

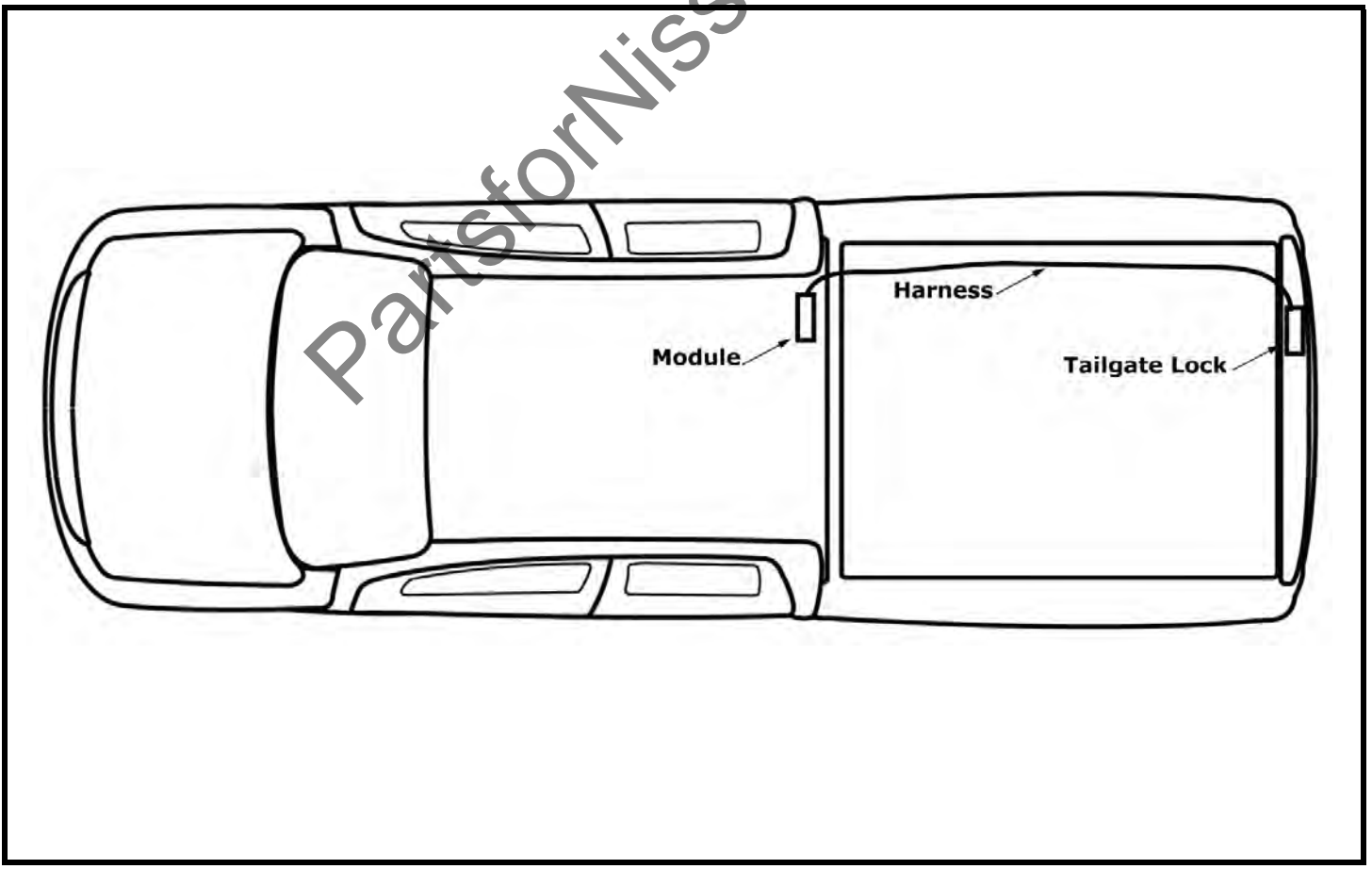

INSTALLATION PROCEDURE: (continued)

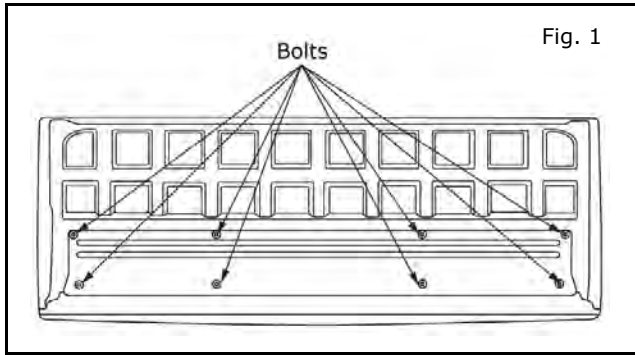

- 1) Remove 8 bolts and remove tailgate access panel. (Figure 1)

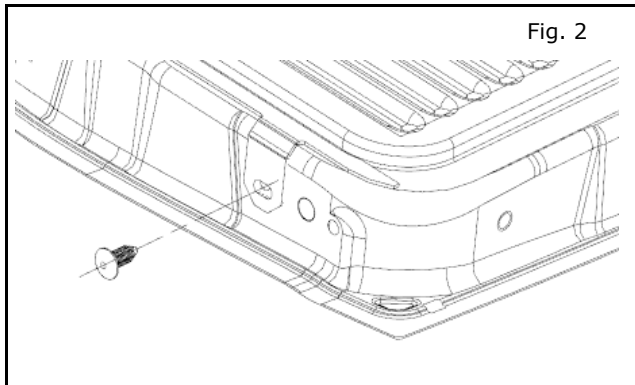

- 2) If tailgate is equipped with cover:
 - a) Remove screws as in Step 1.
 - b) Remove left and right push pin as shown in Fig.2.
 - c) Remove cover and tailgate access panel.

NOTE:

Set the cover aside with the tape facing up where the tape will not get dirty.

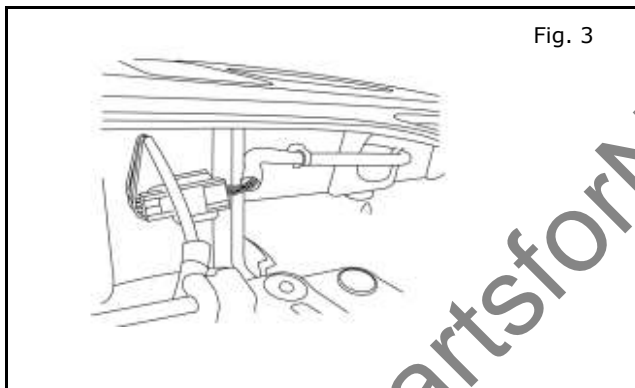

- 3) If tailgate is equipped with rear view camera, disconnect and remove the existing tailgate harness and replace with the kit provided tailgate harness. (Figure 3)

Installation in reverse of removal.

Note:

If tailgate not equipped with rear view camera, install the provided tailgate harness by following reverse of removal steps.

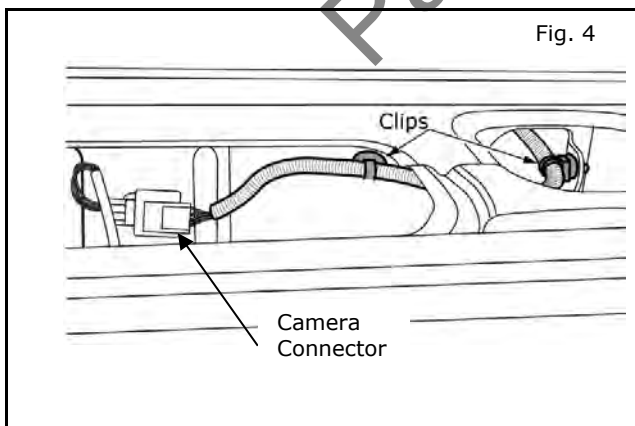

- 4) Disconnect camera connector (if equipped). Disengage 2 XMAS tree clips. (Figure 4)

Notice:

Tailgate Harnesses provided in this kit:

24025 EZ04A part has black tailgate 6-pin conn
-or-
24025 9FT1A part has white tailgate 6-pin conn

-Either harness part is okay to use in the installation.

INSTALLATION PROCEDURE: (continued)

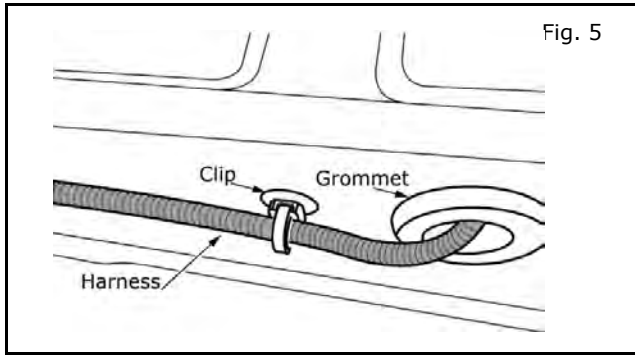

5) Disengage clip and remove grommet.

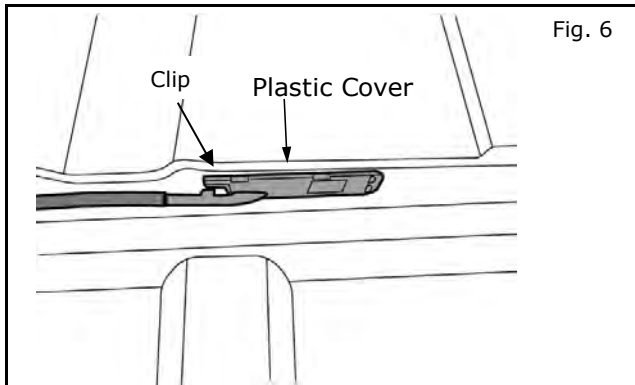

6) Unclip body side plastic cover and disengage from opening. Pull out service length and disconnect inline connector from chassis harness.

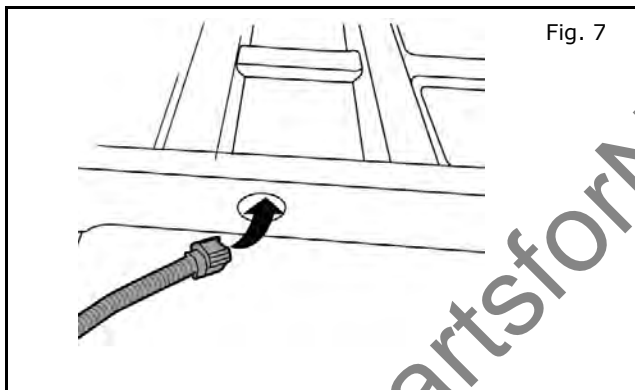

7) Remove original tailgate harness through hole under tailgate.

Replace with kitted tailgate harness. Installation is in reverse of removal.

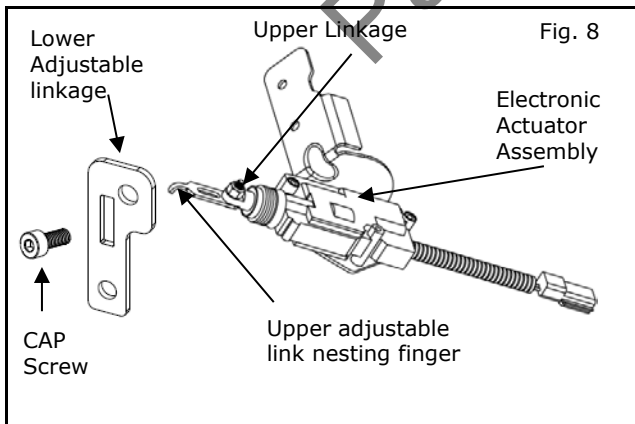

8) Installation preparation:

- a) Obtain Electronic Actuator assembly with upper adjustable linkage section attached with torque applied. (Figure 8)
- b) Obtain lower adjustable linkage section and M4 x 0.7 x 8MM long socket head. Obtain cap screw with thread lock preapplied.

Note:
Clean mating surfaces of linkages with provided alcohol wipe and avoid any further oil contamination there.

INSTALLATION PROCEDURE: (continued)

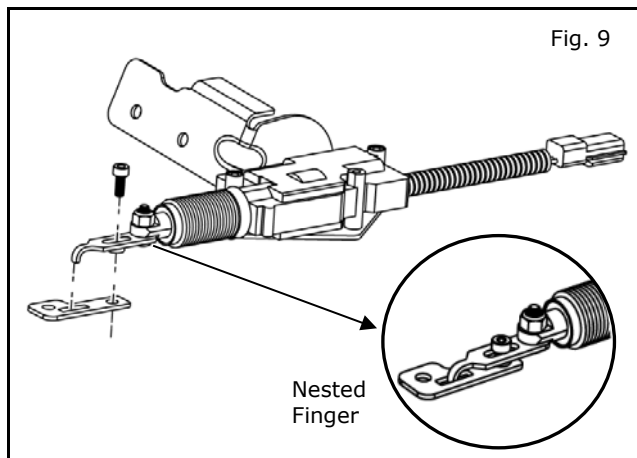

- 9) Hand assemble lower linkage to actuator assembly with provided CAP screw, finger tightening screw while allowing linkage to length adjust freely.

NOTE:

Pay special attention to orientation of the lower adjustable linkage. The nut will be pointing upward. The nesting finger in the upper actuator link is installed into the slot in the lower link as shown. (Figure 9) This assembly can be done off the vehicle.

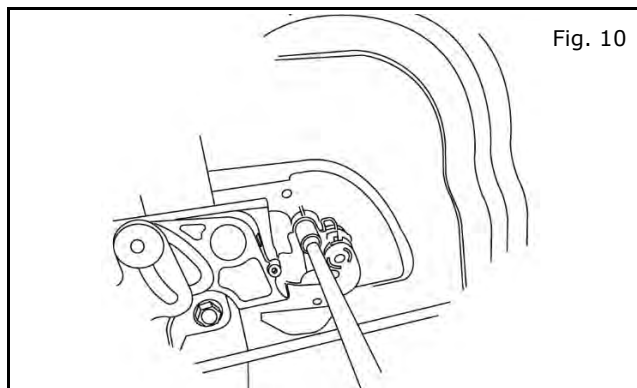

- 10) Install Electronic Actuator assembly onto Key Cylinder lock-rod:

- a) Using 10mm socket and extension, remove key cylinder lock screw. (Figure 10)
- b) Tilting key cylinder lock-rod off alignment peg, remove from slotted plastic tailgate lock lever arm, for ease of installation of electronic actuator. (Figure 10-B)

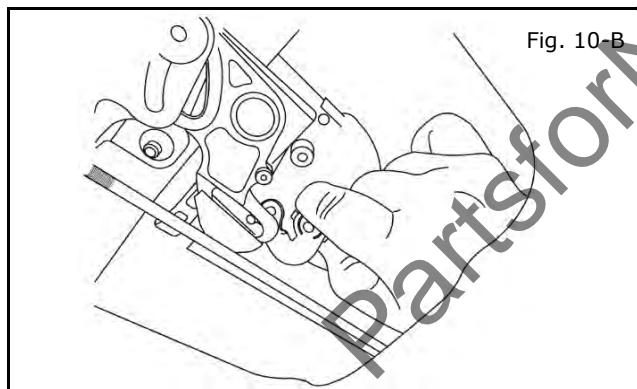

- c) Loosely position actuator link into position between bottom of plastic tailgate lock lever arm and top of key cylinder lock-rod, then reposition key lock cylinder into tailgate handle mechanism and hand tighten key cylinder lock screw.

NOTE:

Pay special attention to orientation of linkage. Ensure M4 socket head CAP screw is pointing outward, so adjustable linkages can be operator adjusted and tightened, as shown (Figure 10-C) All of these features should be visible to the installer.

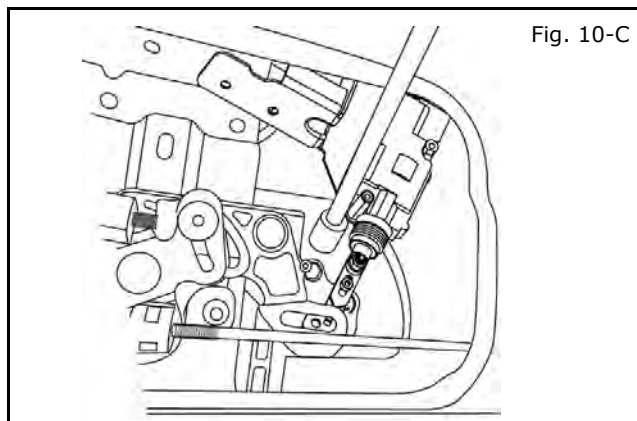

NOTE:

Allow the actuator to lay in the tailgate rotated about 45° CW from its final installation location so that you can install the key lock cylinder and tighten its fastener.

- d) With key cylinder lock-rod in position, torque M5 screw to (5-6.5 Nm) using 10mm socket and extension (Figure 10-C).

INSTALLATION PROCEDURE: (continued)

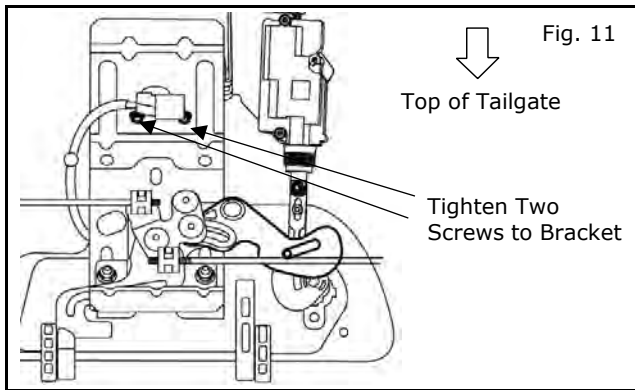

11) **Mounting Electronic Actuator:**

- a) Position actuator bracket CCW under tailgate bracket. Ensure holes on actuator bracket are aligned with predrilled holes on tailgate bracket.
- b) Install two M5 screws to bracket using 8mm swivel socket. Tighten screws to (3.2 - 4.8 Nm.) (Figure 11)

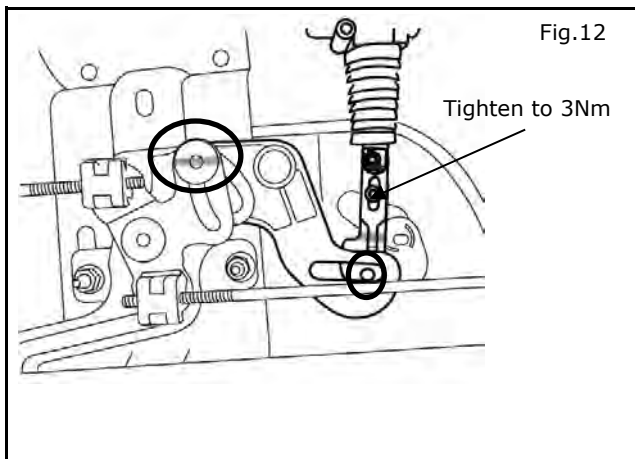

- 12) Move key cylinder lock pin by hand to unlock position (Actuator **FULLY** extended) and allow linkage to rest there.

NOTE:

Key cylinder lock pin should fully reach into the far right most upper corner of plastic tailgate lock lever arm, and actuator linkage should fully reach unlock position (as shown) and stay there in a relaxed state. (Figure 12)

Hold lever arm in place lightly to tighten M4 CAP screw with a 3MM Hex bit socket driver to (3 Nm +/- 0.5 Nm). (Figure 12).

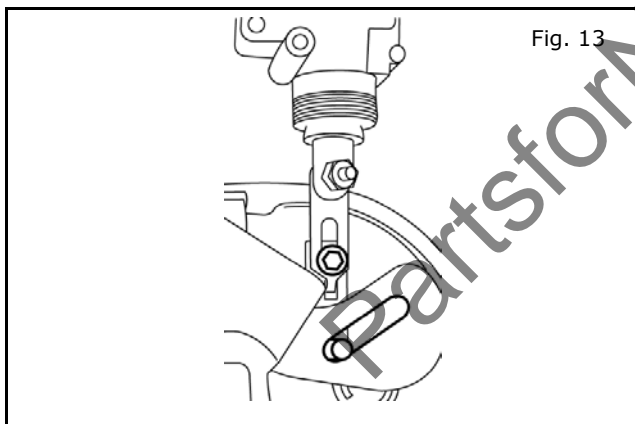

- 13) Return key cylinder lock pin with the key to **lock** position (Actuator **NOT** extended) and let it rest there.

Notice:

The pin should fully reach into the left most corner of the plastic tailgate lock lever arm as shown, and stay there in a relaxed state. (Figure 13)

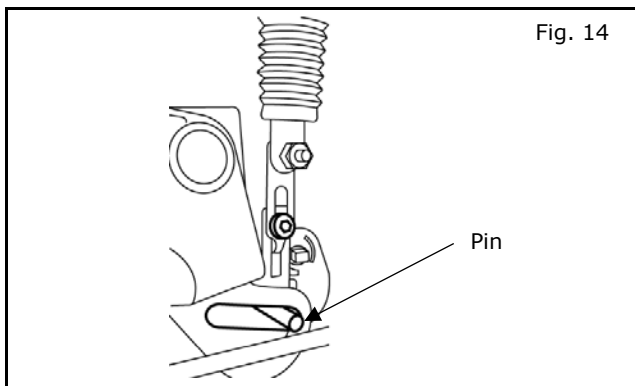

- 14) Move key cylinder lock pin with the key to **unlock** position (Actuator **FULLY** extended) and let it rest there.

NOTE:

The pin should again fully reach into the right most upper corner of the plastic tailgate lock lever arm as shown. (Figure 14)

INSTALLATION PROCEDURE: (continued)

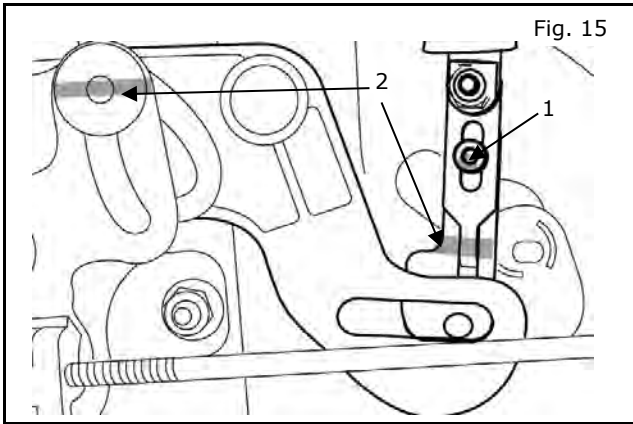

- 15) Cycling with the **key** between unlock position (Actuator **FULLY extended**) and lock position (Actuator **NOT extended**). It should function easily and fully.

Key cylinder lock pin should easily traverse and then rest between (**Unlock = Actuator FULLY extended**) in right most corner of plastic tailgate lock lever arm, and (**Lock = Actuator NOT extended**) with plastic tailgate lock lever arm reaching into left most corner of plastic tailgate lock lever arm.

Notice: Once the alignment is completed:

- 1) The paint mark indicating the M4 CAP screw was torqued as specified.
- 2) Apply paint mark in a manner that bears a witness mark for the position/relationship of both parts at the time of assembly. (Figure 15)

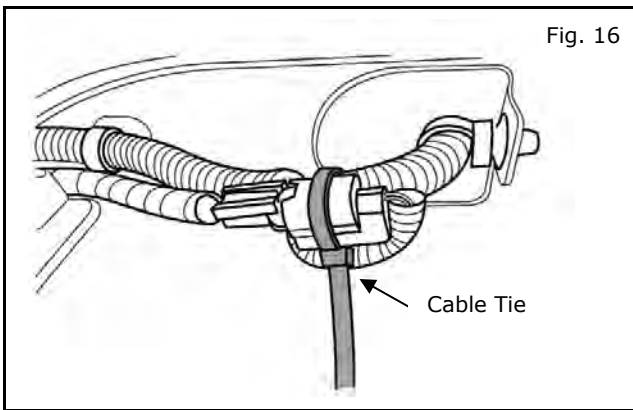

- 16) Connecting harness to actuator.

- a) Connect mating connector on tailgate actuator and secure harness with 8" cable tie. (Fig 16)

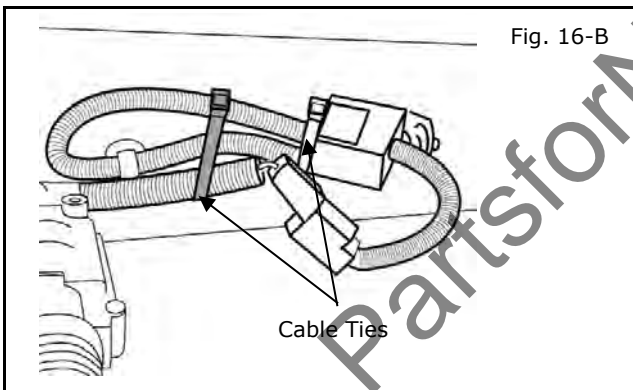

- b) If tailgate is not equipped with rear view camera, bend unused camera connector back and secure with cable ties to tailgate harness as shown. (Fig. 16-B)

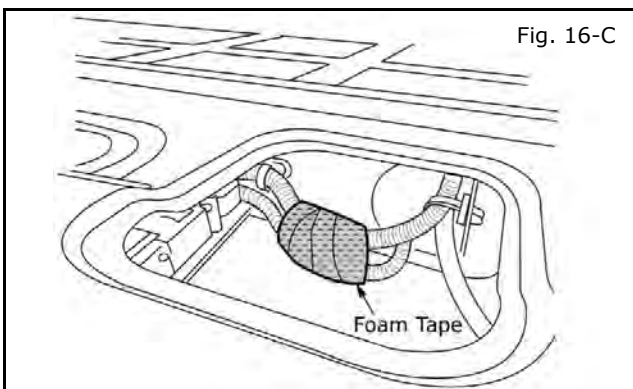

- c) Foam tape inline connectors, to prevent rattle within tailgate. (Fig. 16-C)

INSTALLATION PROCEDURE: (continued)

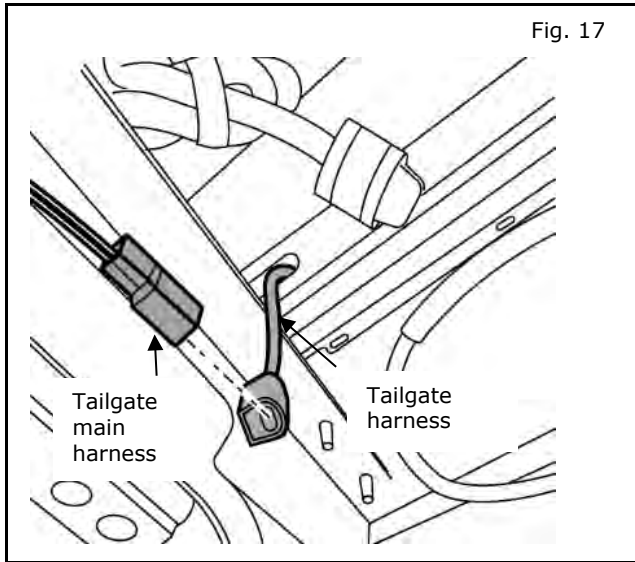

Fig. 17

- 17) Connect tailgate harness to the kit provided tailgate main harness (999M2 W3002). (Figure 17)

NOTE:

- Do not secure either tailgate harness or kit provided tailgate main harness (999M2 W3002) for the first (200 mm = 8 inches) to the vehicle. Wire harness ends must be able to exist in vehicle if customer removes tailgate in normal operation. Length is required to allow customer to access connector from above. (Figure 18)
- Secure inlines so they don't hang or bang around underbody.
- Do not foam tape these inline connectors.

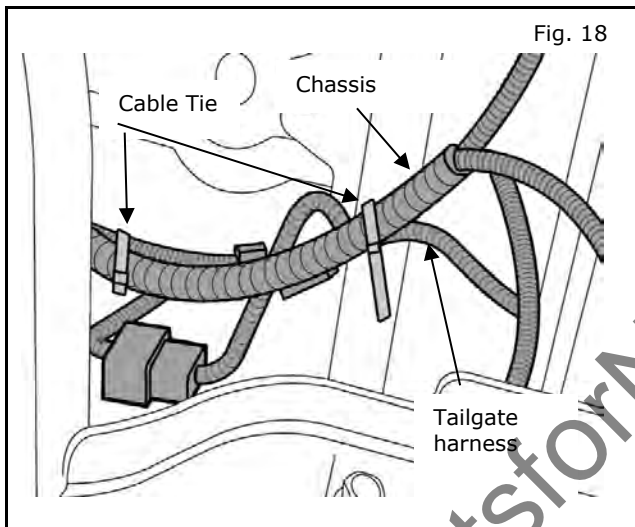

Fig. 18

- 18) Cable tie harness to vehicle chassis harness using two 8" cable ties. (Figure 18)

Note:

- Route main harness along chassis harness as shown in fig 24. Only up until the back of the cab near the grommet. Do not secure with wire ties until step 24.

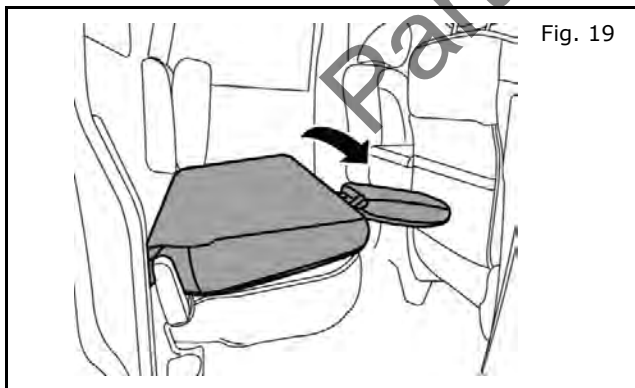
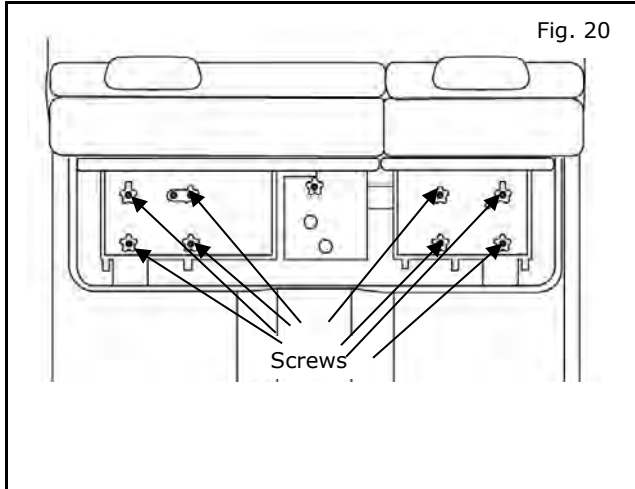

Fig. 19

- 19) Fold down rear passenger seat.

INSTALLATION PROCEDURE: (continued)



20) Vehicles equipped with a storage box:

- a) Remove the under seat storage box, by loosening the retaining screws, using a 10mm hex socket. (Fig 20)

Note:

**Storage Box Screw Torque:
8 N·m (0.82 kg-m, 71 in-lb) (Fig 20)**

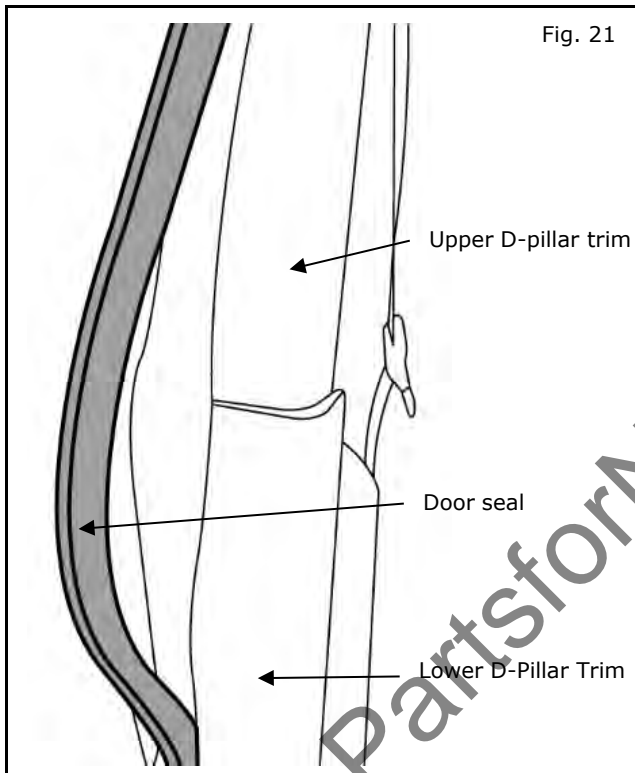

21) Remove door trim seal and trim.

- a) Unclip lower D pillar trim. (Fig 21)
- b) Pull section of rear passenger door seal out and lose up the trim panel. (Fig 21)
- c) Unclip upper D-pillar trim. (Fig 21)

22) Accessing harness pass through hole.

- a) Remove 6 pc panel clip and 2 bolts using 12mm socket. (Figure 22)
- b) Pull back panel for access to hole location with plastic grommet on rear of cab on lower passenger side. (Figures 22 and 22-B)
- c) Remove plastic grommet. (Figure 22-B)

**Note: On Crew Cab (CC) & King Cab (KC)
Seatback Striker Bolt Torque:
23.5 N·m (2.4 kg-m, 17 Ft-lb) (Fig 22)**

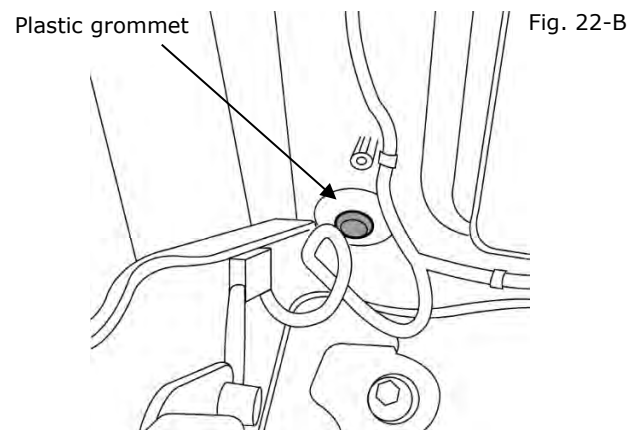
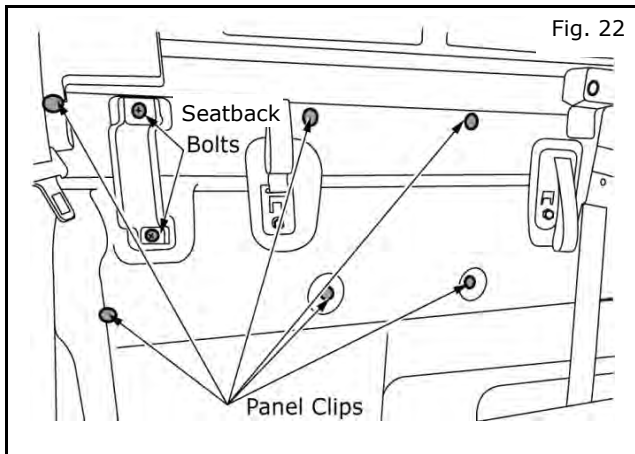

INSTALLATION PROCEDURE: (continued)

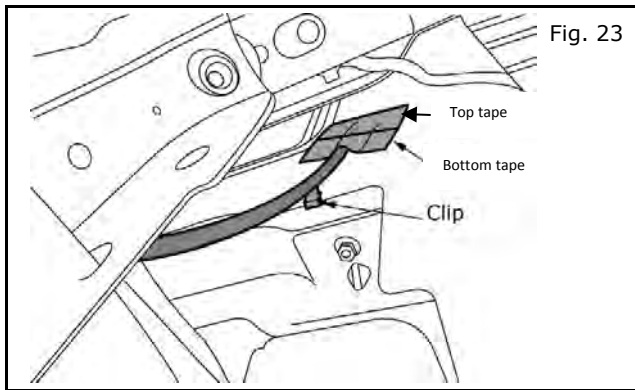

- 23) Route harness into cab.
- Run tailgate main harness with plastic grommet into cab. Ensure blue tape on harness is lined up with grommet.
 - Clean surface with alcohol wipe and apply two blue tapes to cover grommet and harness. Apply bottom tape first then top tape on top of bottom tape. Make sure tape is covering entire grommet.
 - Install **edge biter** clip to body panel to secure harness. (Figure 23)

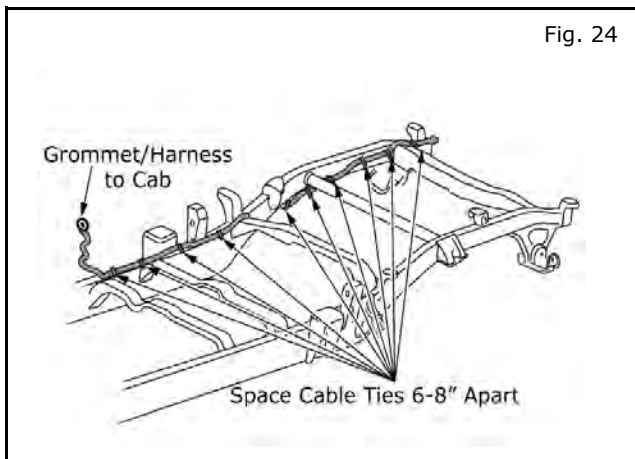

- 24) Securing tailgate main harness to chassis harness.
- Cable tie tailgate main harness every 6-8" to chassis harness. (Figure 24)

Begin at front, stop at position above rear suspension, then from rear and continue to step "b" below.

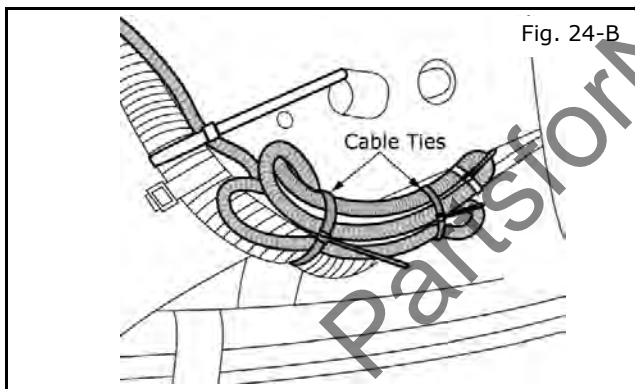

- Bundle excess harness above rear suspension to 6"-8" length and cable tie to chassis harness with two 12" zip ties. Trim excess zip tie. (Figure 24-B)

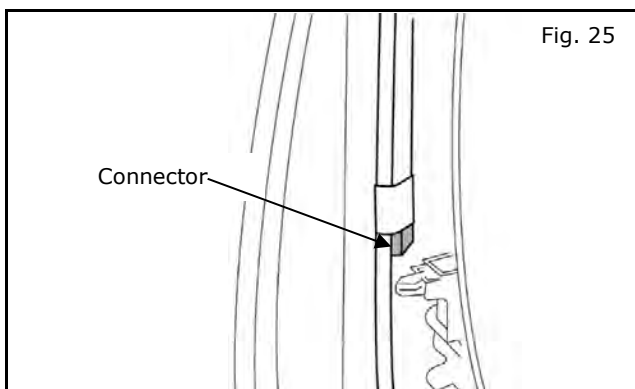

- 25) Locate the white vehicle pre wired connector behind upper D-pillar trim and break away, then cut black tape to pull the connector free. (Figure 25)

NOTE:

It is easier to get to the connector from the back of the trim.

INSTALLATION PROCEDURE: (continued)

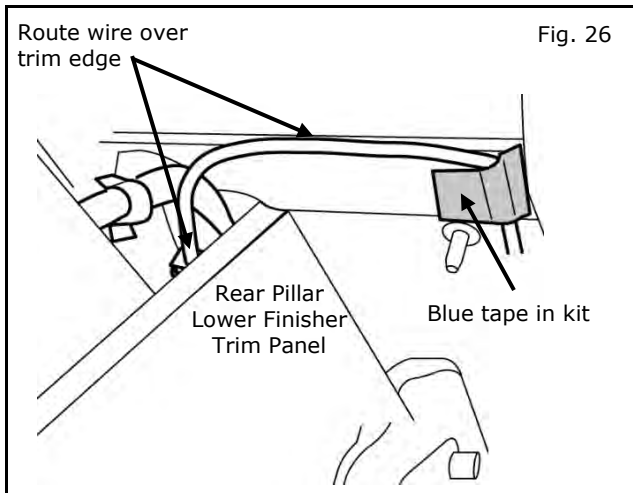

- 26) Connecting relay harness to vehicle pre-wire connector.
- Connect relay harness 999M2 W3003 connector (white NS03) to tailgate pre wire connector (white NS03). Foam tape inline connectors before securing to body harness with cable tie. (Figures 26-28)
 - Route relay harness over the top of the rear pillar lower finisher trim panel. Secure to back cabin panel above and inboard of the threaded stud with blue tape provided in kit. (Figure 26)

NOTE:

Ensure harness is routed from above the vehicle prewire connector of the vehicle; to clear the top of the plastic rear pillar lower finisher trim panel as shown. (Figures 26 & 27)

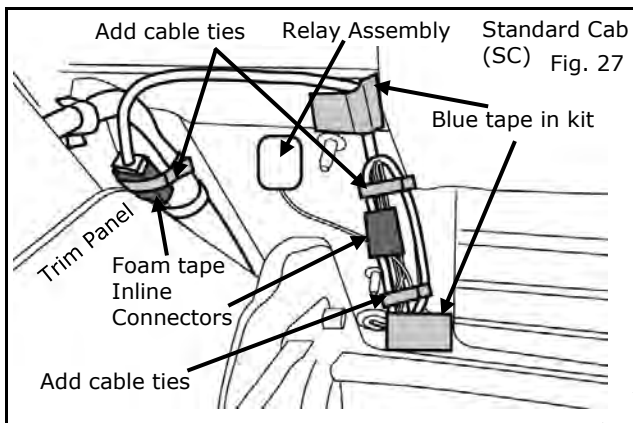

- 27) Connect relay harness to tailgate main harness.
- Connect relay harness 999M2 W3003 connector (Black RH02) to tailgate main harness connector (Black RH02). (Figures 27 - 29)
 - Peel back double sided tape on relay assembly and adhere to body panel. Apply 15 lbs. pressure for 30 seconds. (Figures 27 - 29)
 - Foam wrap inline connectors, secure with blue tape as shown and cable ties as necessary. (Figures 27 - 29)

NOTES:

1) Position of relay assembly on the Standard Cab (SC) is between the cabin vent and the passenger door as shown. Blue tape the main tailgate harness above and inboard of where it comes out of the back cabin panel grommet. Vertically bundle wrap and cable tie all remaining main tailgate harness wire slack, between the back cabin panel grommet and the upper blue tape piece as shown. (Figure 27)

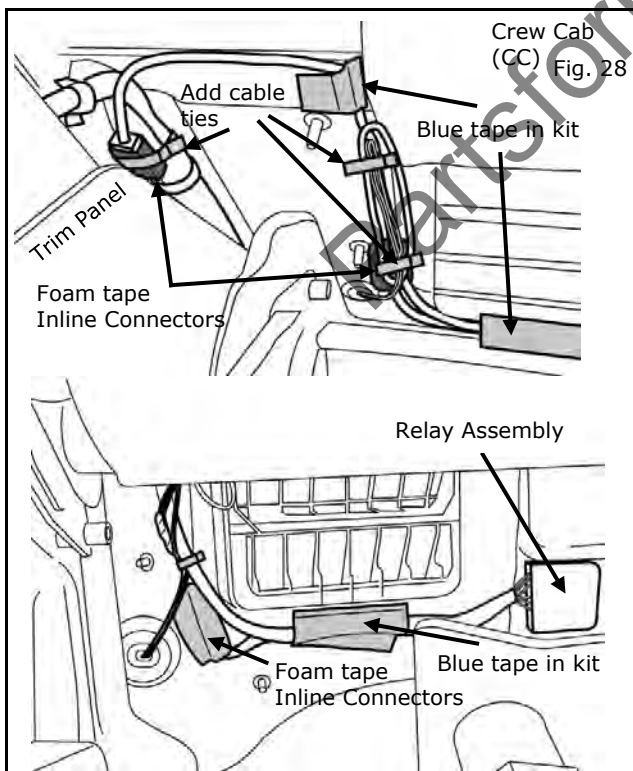

2) Position of relay assembly on Crew Cab (CC) is just inboard of the cabin vent on the back cabin panel as shown. Tape single wire harness section horizontally below the cabin vent onto the back cabin panel. Vertically bundle wrap cable tie all remaining main tailgate harness wire slack, between the back cabin panel grommet and the upper blue tape piece as shown. (Figure 28)

3) Cut off all cable tie ends.

CAUTION

- Do not cable tie the harness to the cabin vent. (Figures 27 - 29)
- Do not horizontally tape or bundle wrap cable tie any remaining main tailgate harness wire slack, below the rear panel studs which are located below the cabin vents. Otherwise it could show, under the installed rear panel trim, when the rear seat is in the raised position. (Figures 28 - 29)

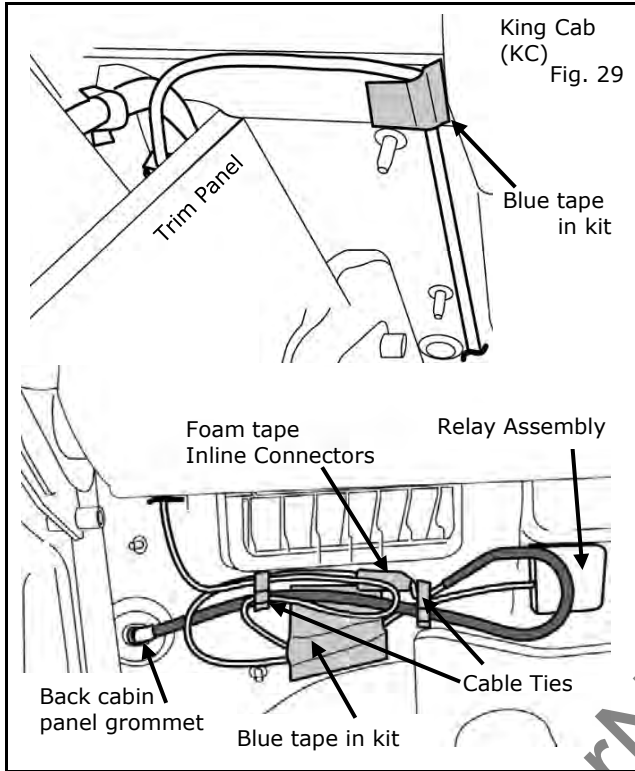

27) Connect relay harness to tailgate main harness.
(Continued)

NOTES:

1) Position of relay assembly on King Cab (KC) is just inboard of the cabin vent as shown. Tape single harness wire, out of the relay assembly, horizontally below the cabin vent onto the back cabin panel. (Figure 29)

2) Bundle wrap cable tie all remaining main tailgate harness wire slack, between the back cabin panel grommet and the relay assembly as shown. (Figure 29)

28) For King Cab vehicles with rear seat delete option.

- a) Remove the rear panel finisher. (Figure 30)
- b) Remove storage box and lid. (Figure 31)
- c) Temporarily fold back the left rear floor carpet to gain access to the rear floor spacer.

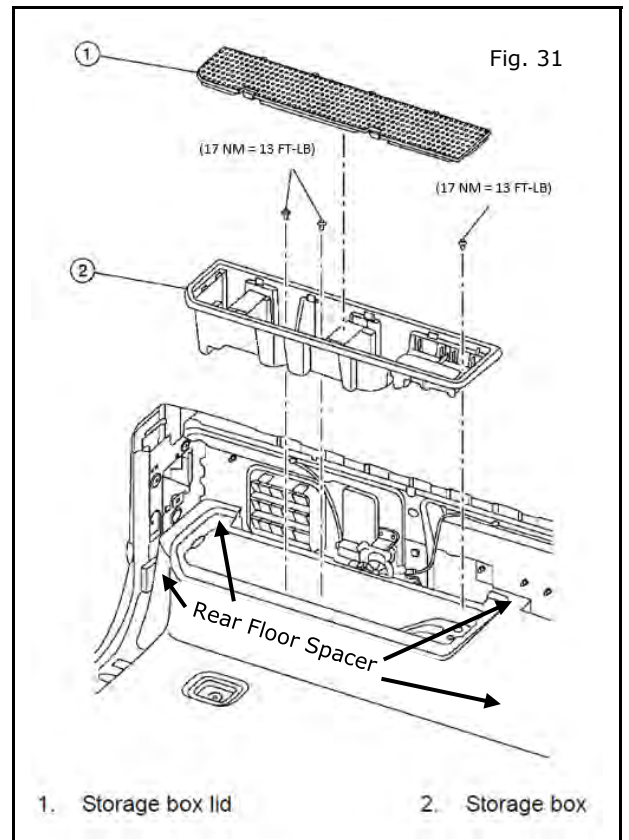
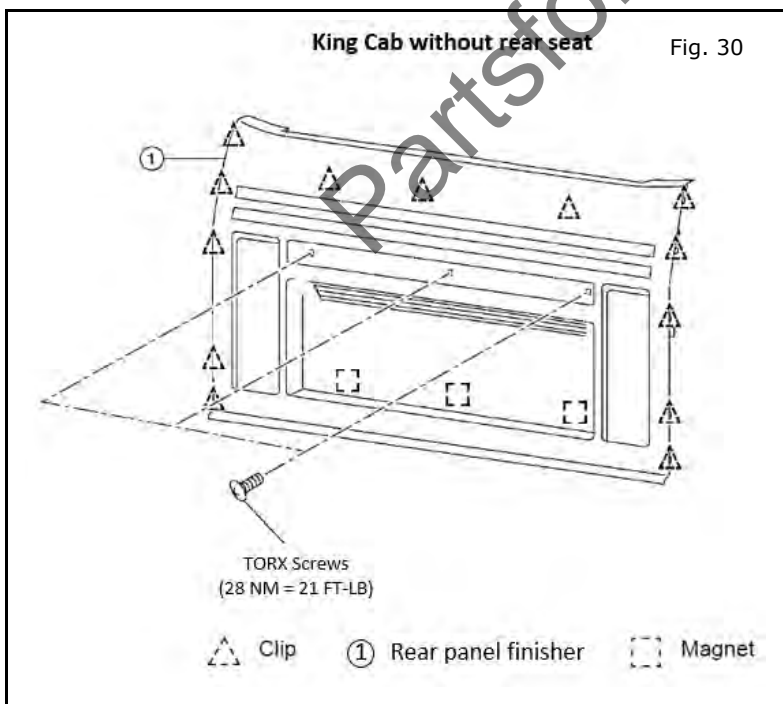

CAUTION

- Notice that the rear floor spacer is blocking the rear panel access pass through hole. (Figure 31)
- The rear floor spacer must be cut out (trimmed) to gain access to the rear panel access hole for the exterior harness to pass from the underbody into the cabin.

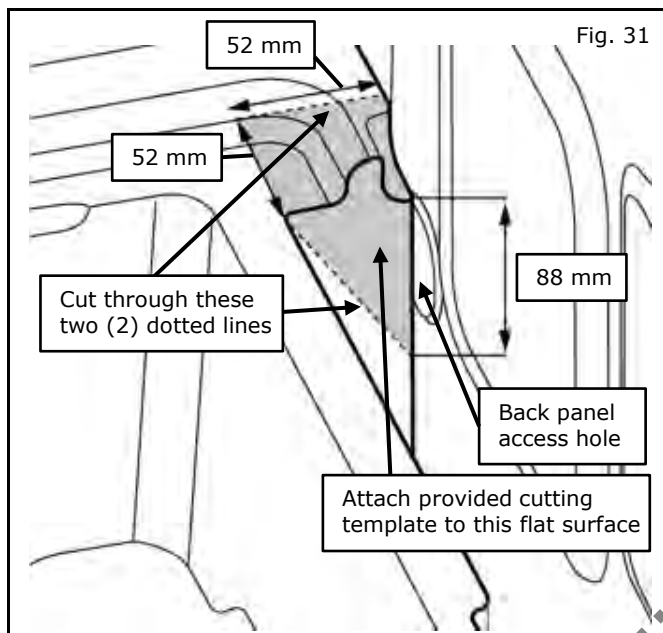

- 29) a) Locate, cutout and use the template. Attach it with tape-or-glue to the flat surface shown. (Figure 31)
- b) Use a suitable cutting tool such as a snap knife, fillet knife, or saw blade to cut a wedge out of the rear floor spacer. (Figure 31)
- c) Two cuts are necessary. One along the template dotted line, and one vertically down 52 mm outboard of the flat surface. (Figure 31)

NOTE:

Cutting away the rear floor spacer is necessary to gain full access to the cabin back panel access hole. Notice the cut point is below the hole. (Figure 30)

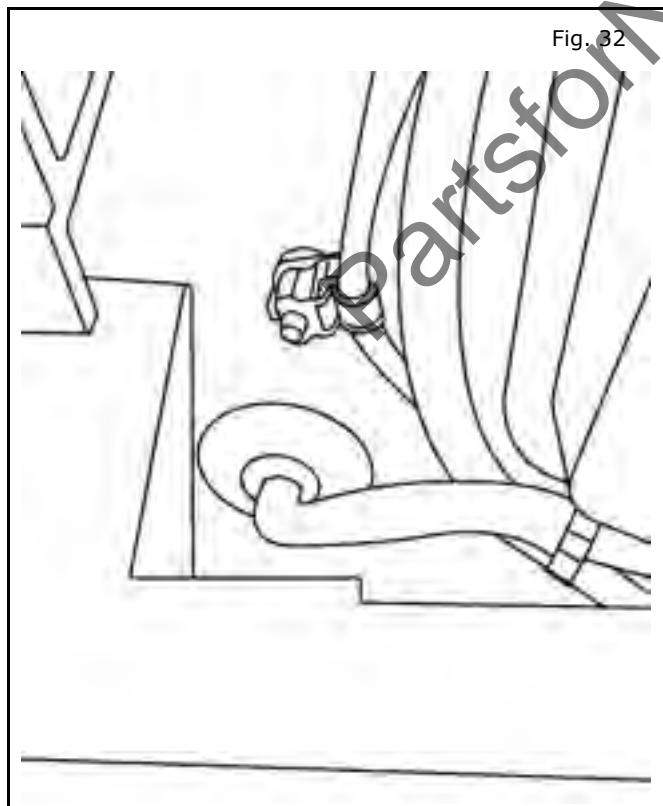

- 30) Connect relay harness to tailgate main harness. (Continued)
- a) Install the harness and relay assembly on King Cab with rear seat delete option as shown. (Figure 32)
- b) Install the harness and relay assembly on King Cab (KC) as previously described. See step # 27, (Figure 29)

FINAL INSPECTION:

- Functional check system
 - Press key fob to lock and check tailgate is locked.
 - Press key fob to unlock all doors and check that tailgate is unlocked.
 - If vehicle is equipped with a rear view camera. Check that the rear camera is functional.
- Reinstall back panel and 6pc push clip. See Figure 22.
- Reinstall bracket and tighten 2 pcs bolt to (20.6 - 26.5 Nm). See Figure 22.
- Reinstall upper trim panel and door seal and lower panel. See Figure 21.
- If this is a Standard Cab vehicle: Reinstall rear underseat storage bin. See Figure 20.
- If this is a King Cab vehicle with the rear seat delete option:
 - a) Replace carpet on top of the rear floor spacer.
 - b) Reinstall storage box and lid and tighten 3 screws to (17 Nm). See Figure 31.
 - c) Reinstall rear panel and tighten 3 torx screws to (28 Nm). See Figure 30.
- Reinstall tailgate access panel and rubber panel if applicable and tighten 8 screws to (1.7-2.0 Nm). See Figures 1 and 2.

PartsforNissans.com

Tailgate Lock

