



# GENUINE PARTS

## INSTALLATION INSTRUCTIONS

**DESCRIPTION:** Front Tow Hooks

**APPLICATION:** Titan XD S, SV 2WD, and SL 2WD

**PART NUMBER:** 999T7 W700B

**KIT CONTENTS:**

Item	Qty.	Part Description	Service Part Number
A	1	Tow Hook RH	51110 1PA0A
B	1	Tow Hook LH	51111 1PA0A
C	4	Hex Bolt - M12 x 45 mm	81-B7245-2A
D	1	Installation Instruction Replacement Template	---



**STOP Important: Read Before Installation!**  
Dealer Installation Recommended.

**⚠ WARNING**  
To avoid serious personal injury or property damage, obtain Installation Instructions before attempting to install this accessory. The Installation Instructions provide the necessary procedures for a safe

**CUSTOMER INTERNET DOWNLOAD INSTRUCTIONS:**  
Customers can obtain Installation Instructions for Infiniti or Nissan vehicles at [www.Infiniti-TechInfo.com](http://www.Infiniti-TechInfo.com) or [www.Nissan-TechInfo.com](http://www.Nissan-TechInfo.com) respectively. From the home page, select Accessory Instructions. Select your Model, Model Year, and Accessory Type or search for your Model, and or Model Year, and or Accessory Type including keyword or Part Number, then locate the Instructions for your accessory.

**DEALER ASSIST DOWNLOAD INSTRUCTIONS:**  
Dealership technicians can locate the Installation Instructions for this accessory by scrolling to and select, "Acc. Install Instructions" tab. Always download and use latest version of the Installation Instructions.

Installation Instructions Replacement Template 999T7 W700B Rev. 07/2015

**TOOLS REQUIRED:**

- 10 mm Socket
- 17 mm Socket
- Ratchet
- Torque Wrench
- 6" Long Socket Extension

**PRE-INSTALLATION WARNINGS, CAUTIONS, CRITICAL STEPS, and NOTES:**

**⚠ CAUTION**

- Dealer installation recommended. Instructions may refer to Service Manual.
- It is recommended that vehicle be raised up on hoist prior to installation of tow hooks.
- Wear safety glasses during entire installation process.

## INSTALLATION PROCEDURE:

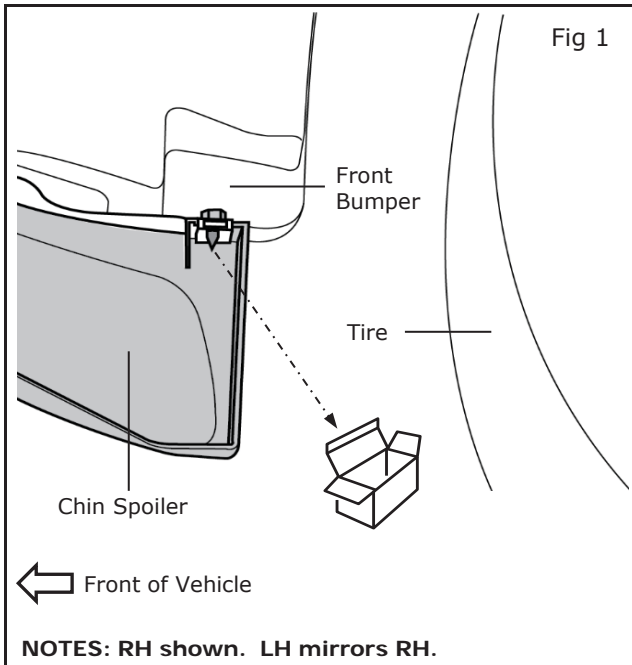

- 1) Remove chin spoiler.
  - a) Using 10mm socket and ratchet, remove and save screw at each lengthwise end of chin spoiler (1 RH and 1 LH). Fig 1.

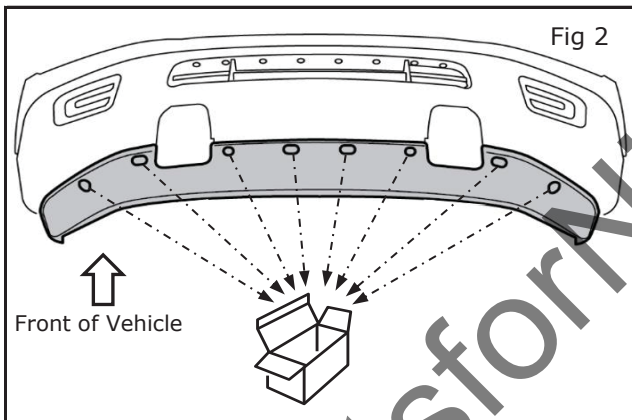

- b) Using 10mm socket, 6" long extension, and ratchet, remove and save 8 bolts from bottom of chin spoiler. Fig 2.

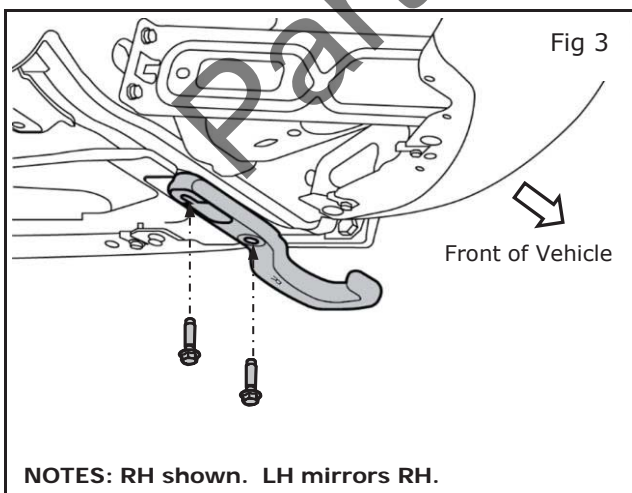

- 2) Install tow hooks.
  - a) Align each tow hook to its mounting points on frame. Fig 3.
  - b) Hand tighten 2 bolts to secure each tow hook. Fig 3.
  - c) Using 17 mm socket and torque wrench, tighten each bolt to 110-150 N·m (81.1-110.6 lbf-ft). Fig 3.

**INSTALLATION PROCEDURE:**

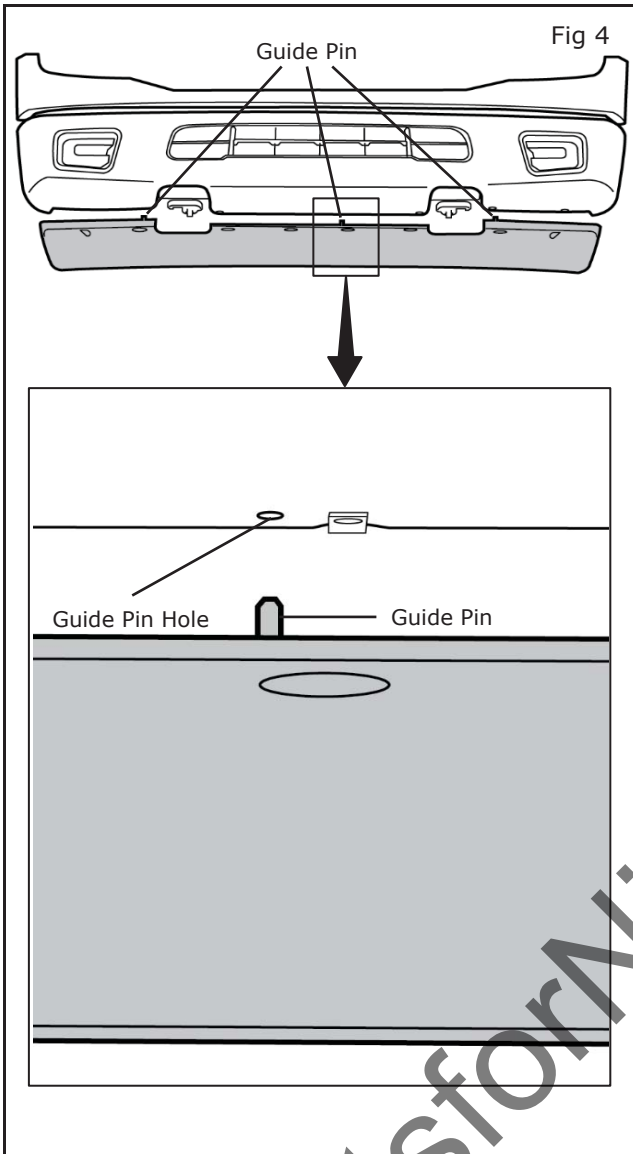

- 3) Reinstall chin spoiler.
- a) Insert 3 chin spoiler guide pins into front bumper guide pin holes. Fig 4.

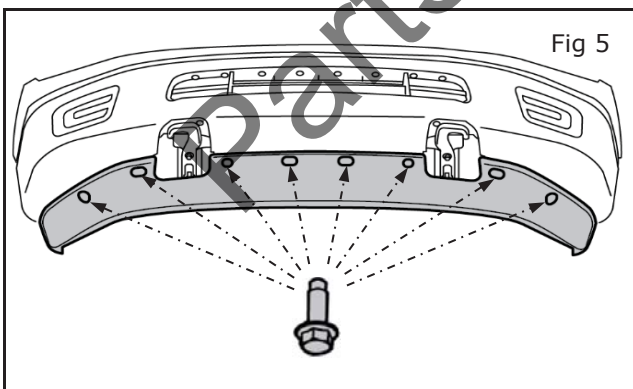

- b) Starting with 2 centermost bolts, hand tighten 8 bolts along bottom of chin spoiler. Fig 5.

**INSTALLATION PROCEDURE:**

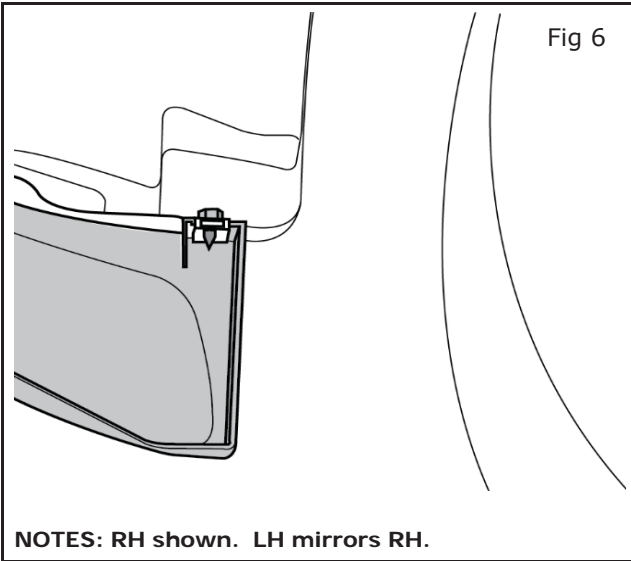

- c) Hand tighten screw at each lengthwise end of chin spoiler (1 RH and 1 LH). Fig 6.
- d) Using 10mm socket and torque wrench, tighten screw at each lengthwise end of chin spoiler (1 RH and 1 LH) to 4.4-6.6 N·m (3.2-4.8 lbf-ft). Fig 6.

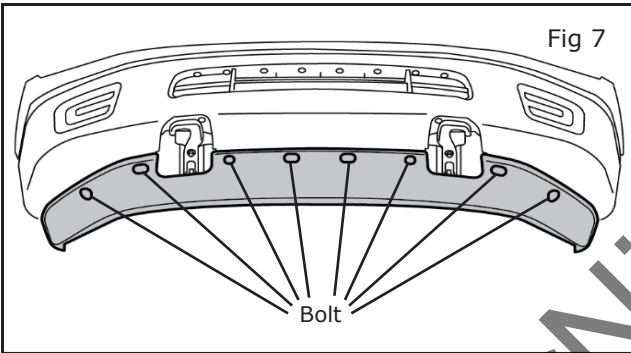

- e) Using 10mm socket, 6" long extension, and torque wrench, tighten each bolt along bottom of chin spoiler to 4.4-6.6 N·m (3.2-4.8 lbf-ft). Fig 7.