



GENUINE PARTS

INSTALLATION INSTRUCTIONS

DESCRIPTION:	Rear Bumper Protector - Black
APPLICATION:	Pathfinder
PART NUMBER:	T99B2 6TA0A

KIT CONTENTS:

Item	Qty.	Part Description	Service Part Number
A	1	Rear Bumper Protector - Black	Available as kit only/kit part number T99B2 6TA0A
B	1	Plastic Squeegee	
C	1	Squeegee Soft Sleeve	
D	1	Installation Instruction Replacement Template	999V2 AW000



A



B

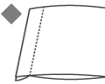

C



D

TOOLS REQUIRED:

- 90% Isopropyl Alcohol
- Dish Soap
- 32 Ounce Spray Bottle
- Water
- Soft Lint Free Microfiber Cloth
- Pin

APPLICATION SOLUTION (FOR PAINTED SURFACE ONLY): Fill a 32 oz. spray bottle with water and add 5-7 drops of dish soap.

PRE-INSTALLATION WARNINGS, CAUTIONS, CRITICAL STEPS, and NOTES:

- Application solution required when applying film to painted bumper surface only.
- Dealer Installation Recommended.
- For proper installation please follow instructions carefully.
- Please DO NOT use or install part in ways other than what is described.
- After installation, do not wash vehicle or expose to moisture for 24 hours. Washing vehicle less than 24 hours after installation can cause poor adhesion.
- The temperature of vehicle body surface and bumper protector must be 18°C - 32°C (65°F - 90°F) for optimal installation.
- Avoid installing bumper protector in direct sunlight, in windy conditions, or near debris producing operations (e.g. spray painting, detailing, blowing leaves, mowing lawn).
- Be careful not to scratch or damage any component during installation or removal.
- Make sure your hands and the application surface are clean and free from any contaminants that can transfer to adhesive.
- Use edges of adhesive liner and premask when handling bumper protector to minimize risk of contaminating adhesive.
- Squeegee must remain in its soft sleeve throughout entire installation process.
- Always use firm overlapping strokes when squeegeeing. Failure to do so can cause bubbles and wrinkles.
- Do not squeegee towards bumper protector areas that have already been properly tacked to vehicle. Failure to do so can cause bubbles and wrinkles.

INSTALLATION PROCEDURE:

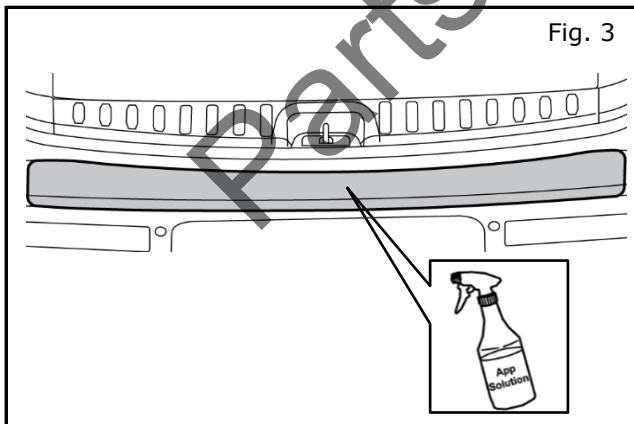
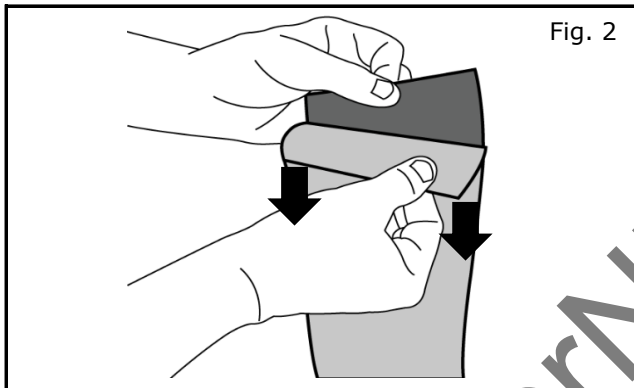
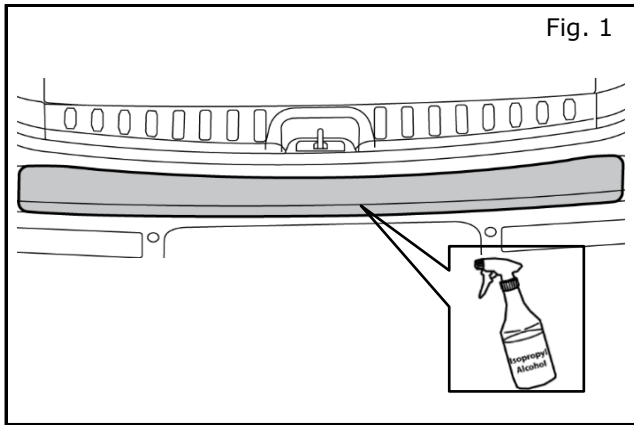

1) Open trunk lid.

2) **Clean Bumper Surface**

With trunk open use the clean lint free microfiber cloth and 90% or greater isopropyl alcohol to clean the bumper application area. Allow to dry completely.

NOTE:

Prevent overspray of the solution which can cause dirt and debris to enter the application surface.

NOTE:

The temperature of the vehicle body surface and bumper protector must be at 18°C - 32°C (65°F - 90°F) for optimal installation

3) Gently shake spray bottle containing application solution.

4) Wet fingers with application solution.

5) **Remove Liner from Film Adhesive**

Lay application film face down on a clean flat surface for support.

Firmly hold premask (top liner) by either hand and slowly peel white liner from film (Bottom Liner). Use any of the handling tabs to steady part as liner is peeled back.

Switch handling tabs as needed and avoid contact with film adhesive.

6) Spray adhesive side of bumper protector with a light even mist of application solution.

7) **Apply Application Solution on painted bumper surface only, if bumper has black grained surface proceed to step 8.**

Spray the cleaned attachment area of rear bumper surface and adhesive film surface with a light even mist of application solution. Take care not to allow application to dry.

NOTE:

Do not allow application solution to dry before bumper protector is properly squeegeed into position. To prevent adhesive from tacking prematurely, regularly lift areas of bumper protector that have not been squeegeed into position to spray a light mist of additional application solution onto adhesive and/or attachment area of rear bumper.

INSTALLATION PROCEDURE:

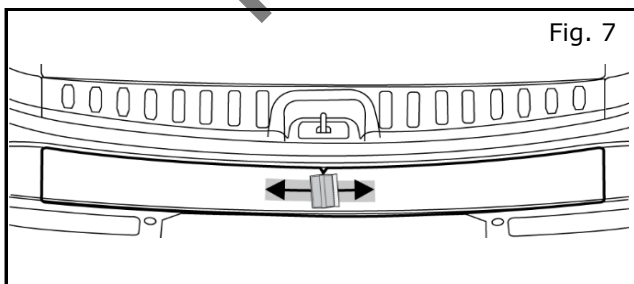
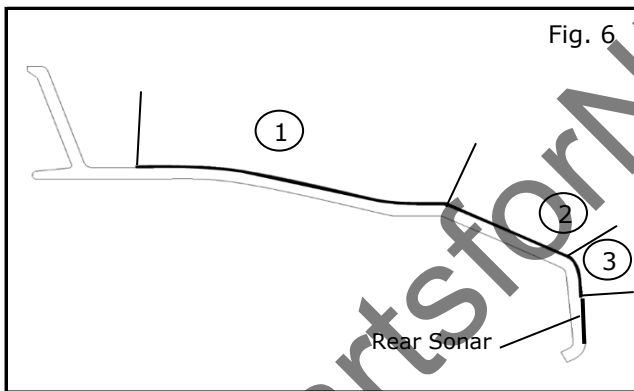
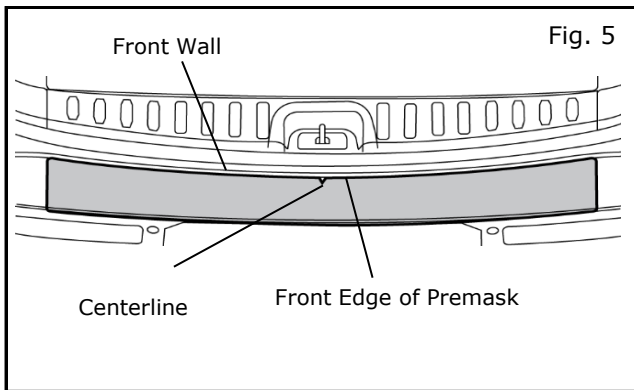
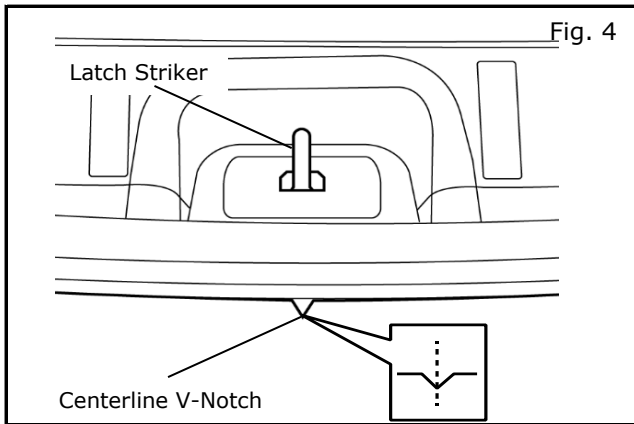

8) Apply Protector Film to Bumper

Align centerline to latch striker.

The Bumper Protector film and bumper should be properly aligned.

Spray top surface of premask with an even mist of application solution to allow the squeegee to slide easily.

NOTE:

Always use squeegee with soft sleeve.

9) Align front edge of premask to bottom of front wall of rear bumper.

10) Squeegee Top Surface

Attachment surface of rear bumper is divided into 3 sections. By following subsequent steps 11 through 16, bumper protector will be squeegeed into position one section at a time according to following sequence: (1) horizontal surface, (2) rounded rear corner edge, and finally (3) vertical surface.

NOTE:

Do not begin squeegeeing until step 11.

NOTE:

If sonar present at vertical surface (section 3) verify bottom of film will not interfere. If contact, remove and realign film.

11) Squeegee Top Surface

Starting from center of top surface, squeegee outward towards right, moving across in 75 mm (3 inch) increments until end is reached. Use lateral overlapping strokes with a force pulling down. Repeat in opposite direction.

Apply firm pressure as you drag squeegee. As liquid is pushed outward from edges, use lint free microfiber cloth to absorb it so that it does not reenter underside of part.

INSTALLATION PROCEDURE:

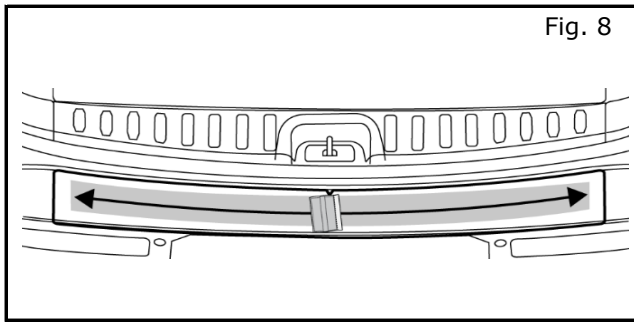

- 12) Working outward from middle of rear slope of horizontal surface, squeegee towards right. Move across rear slope in 150 mm (6 inch) increments until end is reached. Repeat in opposite direction.

NOTE:

Throughout squeegeeing process, use lint free microfiber cloth to absorb liquid as it is squeegeed past outside edges of bumper protector.

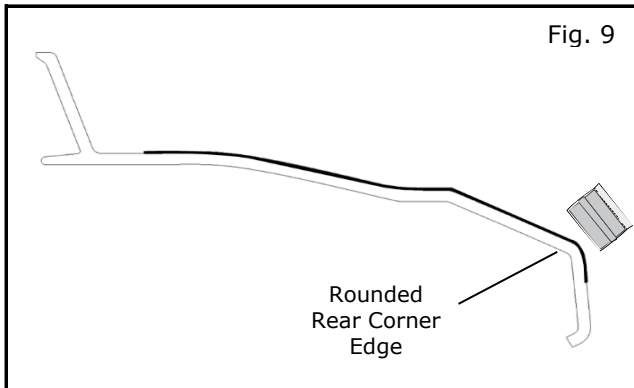

- 13) **Squeegee Rounded Rear Corner Edge**

Working outward from middle of rounded rear corner edge, squeegee towards right. Move across rounded rear corner edge in 150 mm (6 inch) increments until end is reached. Repeat in opposite direction.

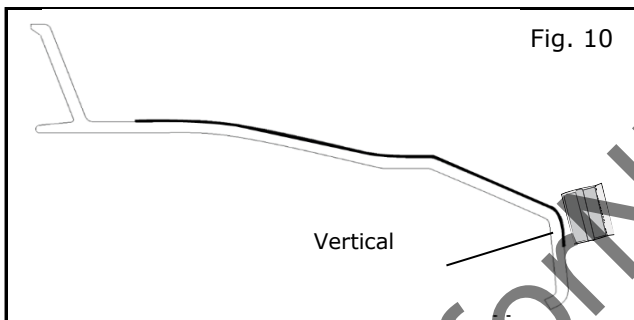

- 14) **Squeegee Vertical Surface**

Squeegee along lower angled surface and smooth out an area about 75 mm (3 inch) to both left and right of part's centerline. Continue to the edge.

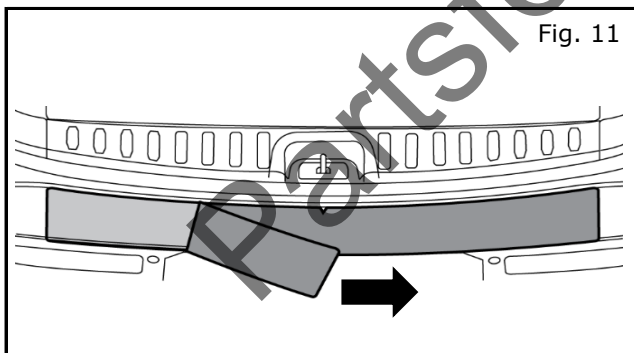

- 15) **Remove Premask**

Carefully remove premask (Top Liner) by pulling slowly and horizontally at 180° angle back against itself. Wipe part and surrounding area of rear bumper with lint free microfiber cloth.

NOTE:

Do not pull upward or outward.

Inspect bumper protector for bubbles and spots that have lifted. Resqueegee troublespots first. If resqueegeeing does not remove bubbles, apply firm pressure with your thumb for 30 seconds on each bubble. If bubbles persist, carefully puncture base of each bubble at an oblique angle. Squeegee out any air or liquid, and wipe with a clean microfiber cloth.

- 16) Do not wash vehicle and avoid exposure to moisture for a minimum of 24 hours.