



GENUINE PARTS

INSTALLATION INSTRUCTIONS

DESCRIPTION: Crossbar
APPLICATION: Pathfinder
PART NUMBER: T99R1 6TA0D (SILVER COLOR) & T99R1 6TA1D (BLACK COLOR)

KIT CONTENTS:

Item	Qty.	Part Description	Service Part Number
A	1	Front Crossbar (Long)	---
B	1	Rear Crossbar (Short)	---
C	8	T-30 Torx Bolt	T98R1 6TA0F-S1 OR T98R1 6TA1F-S1
D	1	T-30 Torx Tool	
E	1	Installation Instructions Replacement Template	
		Crossbar Rubber Pad Replacement Kit (Not Provided)	T99R1 6TA0G-S1

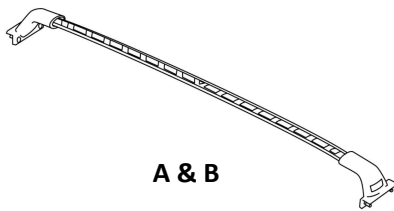

A & B



C

D



E

TOOLS REQUIRED: (Not Provided in Kit)
 ① Torque wrench with T30 Torx tip.
 ② Rag or Soft cloth.

PRE-INSTALLATION WARNINGS, CAUTIONS, CRITICAL STEPS :

- Dealer installation is highly recommended to correctly and safely assemble this part to your vehicle.
- Read through all of the instructions and ensure that all tools stated in the instructions are available before starting installation.
- Removal and re-installation of Crossbars requires re-application of thread locking adhesive LOCTITE® 242® or equivalent on T-30 Torx bolt's.

⚠ CAUTION

- Before installing crossbars, close sunroof and protect painted area on the vehicle roof by placing a piece of cloth under cross bar legs, in order to prevent scratch damage.

INSTALLATION PROCEDURE:

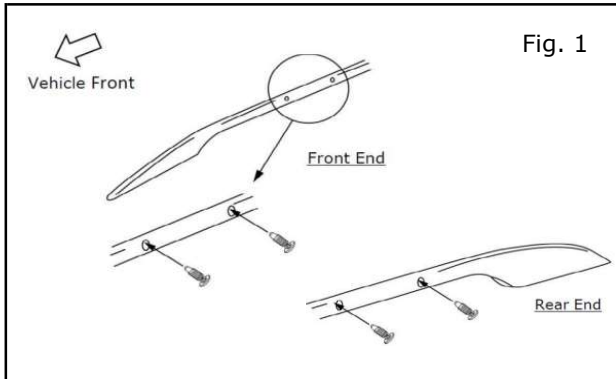

Fig. 1

- 1) Remove 8X plastic plugs from roof rails as shown in Fig 1 using T30 Torx tool (D).

NOTE:

After step 5), Keep plastic plugs & T30 Torx tool (D) in a clear zip lock bag and stow them in glove box for future use if crossbars were removed.

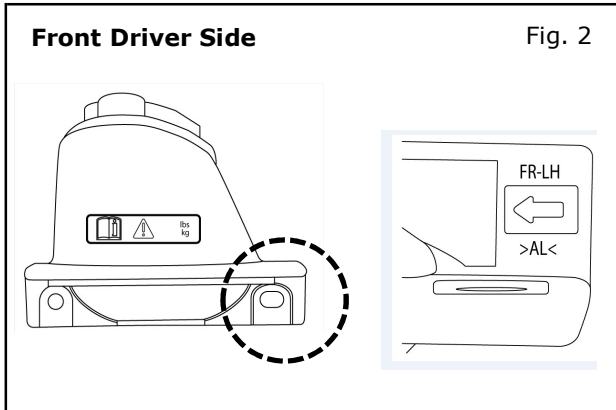

Fig. 2

- 2) Identify the front and rear crossbars with part markings on end support

NOTE:

**FR- LH is front crossbar driver side.
FR- RH is front crossbar passenger side.
RR- LH is rear crossbar driver side.
RR- RH is rear crossbar passenger side.**

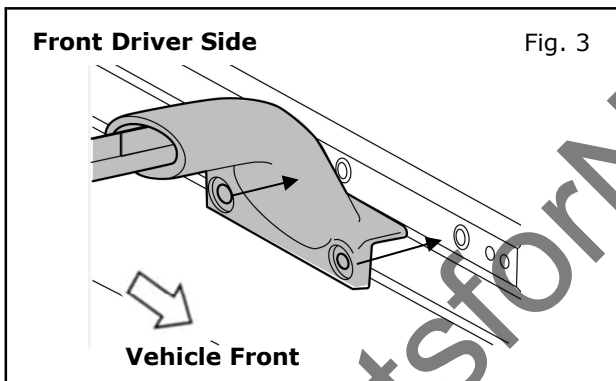

Fig. 3

- 3) Install the front crossbar (A) on the vehicle roof rail by aligning the holes on the end support of crossbar to the threaded holes on roof rail.

NOTE:

The arrow on the crossbar end support should be oriented to vehicle front.

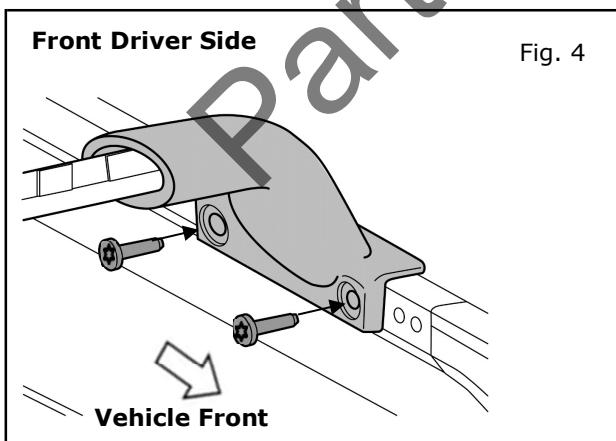

Fig. 4

- 3) While aligned, loosely insert and hand start T-30 torx bolts (C) on both driver side and passenger side.
- 4) With T30 Torx tool (D), tighten all 4X T-30 torx bolts (C).

NOTE:

Please check bolts are torqued to 6.6-7.4 lbf-ft (9-10 N.m) using Torque wrench ①.

⚠ WARNING

- Failure to properly torque bolts to the minimum required value may result in the loss of load and may cause an accident causing severe personal injury, or death.

INSTALLATION PROCEDURE:

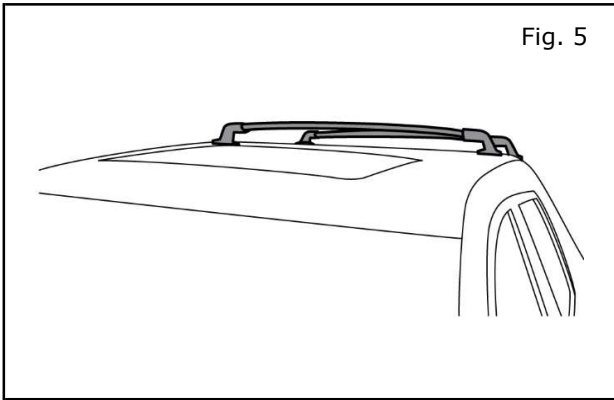

- 5) Repeat steps 1) through 4) for assembly of rear crossbar.
After assembly of both front and rear crossbar, wiggle crossbars with hand to check for loose parts.

NOTE:

If either crossbar is loose, uninstall both the crossbars and repeat the steps 1) through 5) carefully.

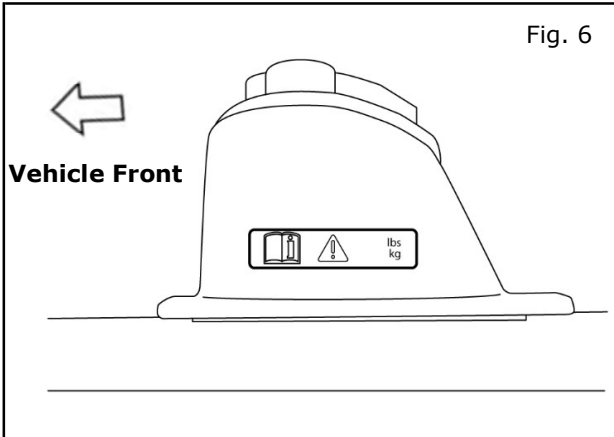

WARNING

- Do not remove load label on driver side end supports.
- Never exceed load rating shown on the load label and always evenly distribute the luggage between front & rear crossbar.
- Be careful that your vehicle does not exceed the Gross Vehicle Weight Rating (GVWR) or its Gross Axle Weight Rating (GAWR Front and Rear). The GVWR and GAWR are located on the Safety Compliance Certification Label (located on the driver side door pillar).
- Always secure roof loading with ropes and cable to prevent it from falling off during driving.
- Do not put load directly on crossbar. To avoid damage to paint and the rubber seal use soft padding or soft cloth on the crossbar before putting rough surface load like plywood, lumber etc.